

Configuring Modem Connectivity with a Cisco 3640 BRI

Document ID: 10307

Introduction

Before You Begin

Conventions

Prerequisites

Components Used

Background Theory

Configure

Network Diagram

Configurations

Verify

Troubleshoot

Troubleshooting Commands

Related Information

Introduction

This configuration supports remote users (for example, a home user or a traveling employee) connecting to the network with an analog dial-up modem using V.90 protocol. Using a PC and an analog modem, the user connects through dial-up PPP to a Basic Rate Interface (BRI) on a Cisco 3640 router. A BRI provides a high speed modem connection and costs less than a Primary Rate Interface (PRI).

Note: Only two async users can dial into each BRI at a time due to the channel limitations on a BRI.

Before You Begin

Conventions

For more information on document conventions, see the Cisco Technical Tips Conventions.

Prerequisites

There are no specific prerequisites for this document.

Components Used

This configuration was developed and tested using the software and hardware versions below.

- Cisco 3640
- Cisco BRI network module (use one of the following):
 - ◆ NM-4B-S/T – Four-port ISDN BRI network module, minimum version 800-01236-03
 - ◆ NM-4B-U – Four-port ISDN BRI with integrated NT-1 network module, minimum version 800-01238-06
 - ◆ NM-8B-S/T – Eight-port ISDN BRI network module, minimum version 800-01237-03

- ◆ NM-8B-U – Eight-port ISDN BRI with integrated NT-1 network module, minimum version 800-01239-06
- Digital modem network module (use one of the following: NM-6DM, NM-12DM, NM-18DM, NM-24DM, or NM-30DM)
- LAN interface card
- Cisco IOS® Software Release 12.0(2)XC

For more information regarding minimum hardware and software requirements (for example, part numbers and revision numbers), see the Modem over ISDN BRI for the Cisco 3640 Router documentation.

The information presented in this document was created from devices in a specific lab environment. All of the devices used in this document started with a cleared (default) configuration. If you are working in a live network, ensure that you understand the potential impact of any command before using it.

Background Theory

This configuration uses a local user list for access security on the Cisco router.

Below are the relevant sections of the show version command output with the Cisco IOS Software version and the modem firmware versions used to implement this configuration:

```
Cisco Internetwork Operating System Software IOS (tm) 3600 Software (C3640-I-M), Version 12.0(2)XC  
System image file is "flash:c3640-i-mz.120-5.XK1"  
MICA-6DM Firmware: CP ver 2310 - 6/3/1998, SP ver 2310 - 6/3/1998.
```

Use the **show diag EXEC** command to determine the type of hardware installed in your router. The **show diag** command displays the version number as well as the part number of the hardware modules in the router. Following is the relevant section of the sample output from the **show diag EXEC** command:

```
maui-nas-04#show diag  
  
Slot 1:  
BRI (U) port adapter, 4 ports  
Serial number 17156199 Part number 800-01238-06
```

Configure

In this section, you are presented with the information to configure the features described in this document.

Note: To find additional information on the commands used in this document, use the IOS Command Lookup tool

Network Diagram

This document uses the network setup shown in the diagram below.

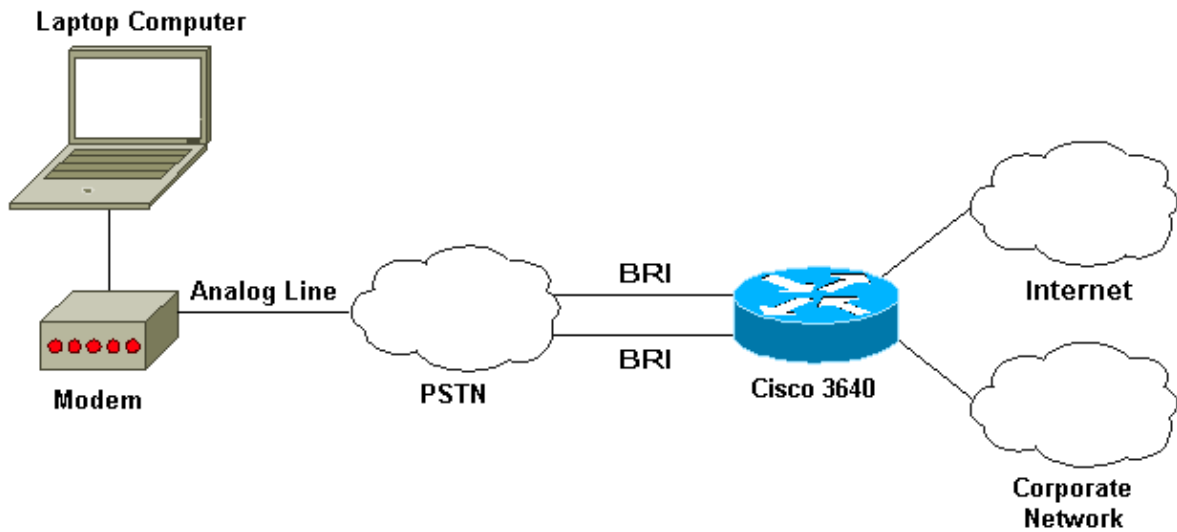

Configurations

This document uses the configurations shown below.

Cisco 3640
<pre> maui-nas-04#show run Building configuration... Current configuration: ! ! Last configuration change at 10:11:43 CST Thu Apr 13 2000 ! version 12.0 service timestamps debug uptime service timestamps log uptime service password-encryption ! hostname maui-nas-04 ! aaa new-model AAA authentication login default group tacacs+ local AAA authentication ppp default if-needed group tacacs+ local ! enable secret <deleted> ! username admin privilege 15 password 7 0213100D52050024 ! modem country mica <country> !-- The country information is mandatory for the configuration to work ! clock timezone CST -6 clock summer-time CST recurring ! ip subnet-zero ip domain-name maui-onions.com ip name-server 172.22.53.210 ! isdn switch-type basic-ni ! --- Global ISDN switchtype </pre>

```

!
!
process-max-time 200
!
interface Loopback0
 ip address 172.22.87.4 255.255.255.0
 no ip directed-broadcast
!
interface Loopback1
 no ip address
 no ip directed-broadcast
!
interface Ethernet0/0
 ip address 172.22.80.4 255.255.255.0
 no ip directed-broadcast
!
interface Ethernet0/1
 no ip address
 no ip directed-broadcast
 shutdown
!
interface BRI1/0
 no ip address
 no ip directed-broadcast
 shutdown
 isdn switch-type basic-ni
!
interface BRI1/1
 no ip address
 no ip directed-broadcast
 shutdown
 isdn switch-type basic-ni
!
interface BRI1/2
 no ip address
 no ip directed-broadcast
 shutdown
 isdn switch-type basic-ni
!
interface BRI1/3
! --- Active BRI

 no ip address
 no ip directed-broadcast
 isdn switch-type basic-ni
 isdn spid1 51255511110101 5551111
 isdn spid2 51255522220101 5552222
 isdn incoming-voice modem

! --- Direct incoming voice calls to the modems
! --- Add the above command to all BRIs that will accept analog calls

!
interface Group-Async1
 ip unnumbered Loopback0

! --- Loopback0 is assigned above

 no ip directed-broadcast
 encapsulation ppp
 async mode interactive
 peer default ip address pool default

! --- Use local pool defined below

```

```

ppp authentication pap
! --- Use PAP authentication

group-range 65 66

! --- Line range is configured below

!
router eigrp 69
network 172.22.0.0
!
ip local pool default 172.22.84.2 172.22.84.253

! --- IP address pool assignment

ip default-gateway 172.22.80.1
ip classless
ip route 0.0.0.0 0.0.0.0 172.22.80.1
ip http server
ip http authentication local
!
tacacs-server host 172.22.53.201
tacacs-server key <deleted>
!
line con 0
transport input all
line 65 66

! --- This must match the group-range in the Group-Async Interface
! --- Use the show line command to determine which lines are to be configured for dialin

autoselect during-login
autoselect ppp
modem Dialin
line 67 70
line aux 0
line vty 0 4
password
!
ntp clock-period 17179861
ntp server 172.22.255.1 prefer

end

```

Verify

This section provides information you can use to confirm your configuration is working properly.

Certain **show** commands are supported by the Output Interpreter tool, which allows you to view an analysis of **show** command output.

- **show isdn stat** – The status should be:

```

layer 1 = active
layer 2 = MULTIPLE_FRAMES_ESTABLISHED

```

If Layer 1 is not active, the wiring adapter or port may be damaged or not plugged in. If Layer 2 is in a state of TEI_Assign, the router is not talking to the switch.

- **show line** – To display the parameters of the lines. Use the **show line** command to decide which lines need to be configured for dial in.

- **show users** – To display the line number, connection name, idle time, and terminal location.
- **show diag** – To determine the type of hardware installed in your router.

Troubleshoot

This section provides information you can use to troubleshoot your configuration.

Troubleshooting Commands

Note: Before issuing **debug** commands, please see Important Information on Debug Commands.

- **debug modem** – To observe modem line activity on an access server.
- **debug modem csm** – To debug the call state machine used to connect calls on the modem.
- **debug isdn Q931** – To check ISDN connections as users dial in to see what is happening with the ISDN call (for example, if the connection is being dropped).

Related Information

- **Modem over ISDN BRI for the Cisco 3640 Router**
- **Configuring Modem Support and Other Asynchronous Features**
- **Technical Support – Cisco Systems**

[Contacts & Feedback](#) | [Help](#) | [Site Map](#)

© 2007 – 2008 Cisco Systems, Inc. All rights reserved. [Terms & Conditions](#) | [Privacy Statement](#) | [Cookie Policy](#) | [Trademarks of Cisco Systems, Inc.](#)

Updated: Sep 09, 2005

Document ID: 10307
