



CHAPTER 4

Call Park and Directed Call Park

This chapter describes the Call Park feature, which is a hold function, and the Directed Call Park feature, which is a transfer function. Cisco recommends that you treat these two features as mutually exclusive: enable one or the other, but not both. If you do enable both, ensure that the numbers that are assigned to each are exclusive and do not overlap. The information in the following sections will help you utilize these two features to their maximum potential:

- [Call Park](#)
- [Directed Call Park](#)

Call Park

The Call Park feature allows you to place a call on hold, so it can be retrieved from another phone in the Cisco Unified Communications Manager system (for example, a phone in another office or in a conference room). If you are on an active call at your phone, you can park the call to a call park extension by pressing the Park softkey or the Call Park button. Someone on another phone in your system can then dial the call park extension to retrieve the call.

You can define either a single directory number or a range of directory numbers for use as call park extension numbers. You can park only one call at each call park extension number.

This chapter provides the following information about call park:

- [Introducing Call Park, page 4-2](#)
- [System Requirements for Call Park, page 4-4](#)
- [Interactions and Restrictions, page 4-5](#)
- [Installing and Activating Call Park, page 4-8](#)
- [Configuring Call Park, page 4-8](#)
- [Setting the Service Parameters for Call Park, page 4-9](#)
- [Finding a Call Park Number, page 4-10](#)
- [Configuring a Call Park Number, page 4-11](#)
- [Call Park Configuration Settings, page 4-11](#)
- [Deleting a Call Park Number, page 4-12](#)
- [Related Topics, page 4-24](#)

Introducing Call Park

The Call Park feature works within a Cisco Unified Communications Manager cluster, and each Cisco Unified Communications Manager in a cluster must have call park extension numbers defined. (For information about using call park across clusters, see the [“Using Call Park Across Clusters”](#) section on page 4-3.) You can define either a single directory number or a range of directory numbers for use as call park extension numbers. Ensure that the directory number or range of numbers is unique.

Valid call park extension numbers comprise integers and the wildcard character, X. You can configure a maximum of XX in a call park extension number (for example, 80XX), which provides up to 100 call park extension numbers. When a call gets parked, Cisco Unified Communications Manager chooses the next call park extension number that is available and displays that number on the phone.

Cisco Unified Communications Manager can park only one call at each call park extension number.

**Note**

If users will use call park across servers in a cluster, ensure each Cisco Unified Communications Manager server in a cluster has call park extension numbers that are configured. See the [“Configuring a Call Park Number”](#) section on page 4-11 for configuration details.

Using the Call Park Feature

Figure 4-1 illustrates the call park process.

1. User on phone A calls phone B.
2. User on phone A wants to take the call in a conference room for privacy. Phone A user presses the Park softkey.
3. The Cisco Unified Communications Manager server to which phone A is registered sends the first available call park directory, 1234, which displays on phone A. The user on phone A watches the display for the call park directory number (so he can dial that directory number on phone C).
4. The user on phone A leaves the office and walks to an available conference room where the phone is designated as phone C. The user goes off-hook on phone C and dials 1234 to retrieve the parked call.
5. The system establishes call between phones C and B.

Figure 4-1 Call Park Process

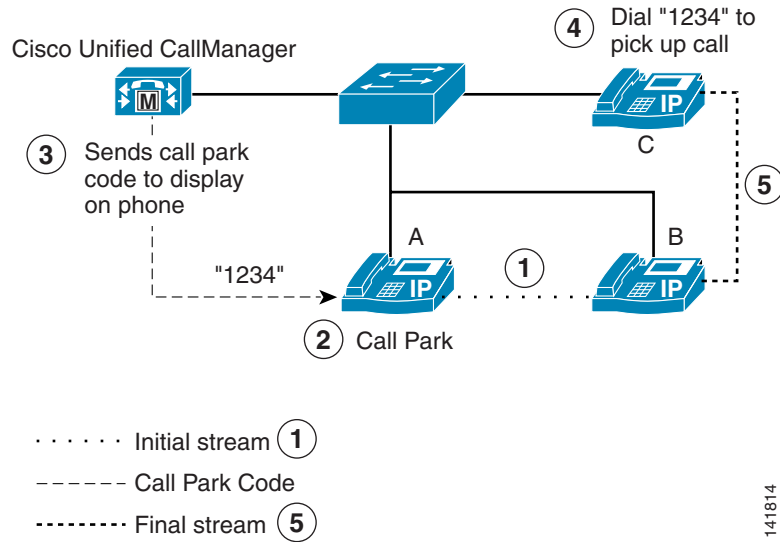

Using Call Park Across Clusters

Users can dial the assigned route pattern (for example, a route pattern for an intercluster trunk could be 80XX) and the call park number (for example 8022) to retrieve parked calls from another Cisco Unified Communications Manager cluster. Additionally, you must ensure that calling search spaces and partitions are properly configured.

See the following example.

Example of Retrieving Parked Calls from Another Cluster

Two clusters exist in the network (cluster A and cluster B). Cluster A includes user A1 and user A2. Cluster B includes user B1 and user B2.

Cluster A includes call park numbers in the range of 81xx. Cluster B includes call park numbers in the range of 82xx, which the administrator configured.

Cluster A includes route patterns that are configured to other cluster park ranges as 82xx (routes to Cluster B). Cluster B includes route patterns that are configured to other cluster park ranges as 81xx (routes to Cluster A).

When user A1 parks a call at 8101, all users (which have correct partitions configured) in Cluster A and Cluster B can retrieve the parked call because of the route pattern configuration. When user B1 parks a call at 8202, all users (which have correct partitions configured) in Cluster A and Cluster B can retrieve the parked call because of the route pattern configuration. See [Figure 4-2](#).

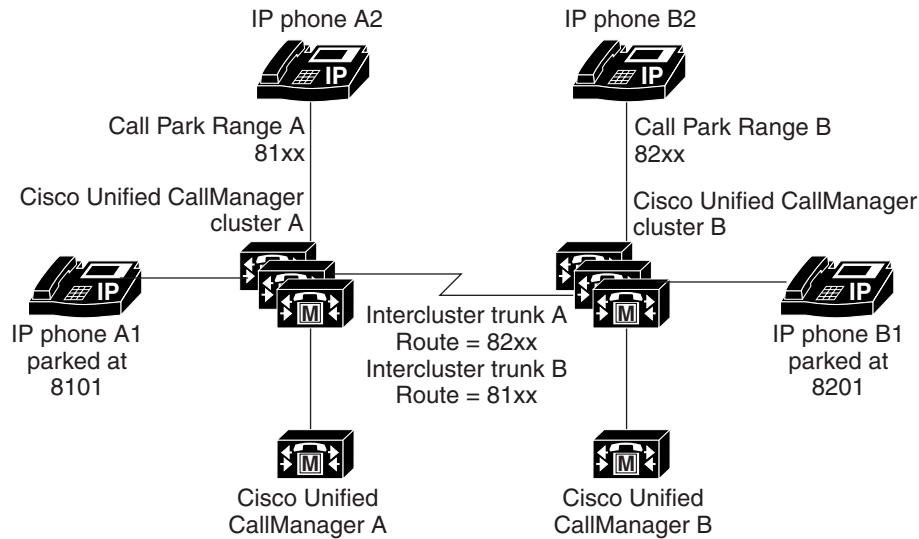
Figure 4-2 Retrieving Parked Calls by Using Intercluster Trunks**Example 1**

1. A1 and A2 talk in connected state.
2. A1 parks call at 8101.
3. B1 dials 8101, call gets routed to cluster A.

Example 2

1. B1 and B2 talk.
2. B1 parks call at 8201.
3. A1 dials 8201 to retrieve parked call.

Intercluster Trunk A includes Route 82xx that accesses Intercluster Trunk to Cluster B
 Intercluster Trunk B includes Route 81xx that accesses Intercluster Trunk to Cluster A

Note: Users do not have control of the parked call number; the system assigns the number.

141815

Additional Information

See the [“Related Topics”](#) section on page 4-24.

System Requirements for Call Park

To operate, call park requires the following software component:

- Cisco Unified Communications Manager

The following phones that are running SCCP and phones that are running SIP support call park with the Park softkey in the Standard User and Standard Feature softkey templates:

- Cisco Unified IP Phones (7941, 7961, 7970, 7971)

The following phones that are running SCCP support call park with the Park softkey in the Standard User and Standard Feature softkey templates:

- Cisco Unified IP Phones (7905, 7912, 7920, 7931, 7940, 7960)



Note You can configure Call Park on any line (except line 1) or button by using the programmable line key feature.

The following phones that are running SCCP support call park with the Call Park button on the phone button template:

- Cisco Unified IP Phone 30 (30 SP+ and 30 VIP)
- Cisco Unified IP Phone 12 (12 S, 12 SP, 12 SP+)
- Cisco Unified IP Phone 7910

Additional Information

See the [“Related Topics” section on page 4-24](#).

Interactions and Restrictions

The following sections describe the interactions and restrictions for call park:

- [Interactions, page 4-5](#)
- [Restrictions, page 4-7](#)

Interactions

The following sections describe how call park interacts with Cisco Unified Communications Manager applications and call processing:

- [Attendant Console, page 4-5](#)
- [CTI Applications, page 4-6](#)
- [Music On Hold, page 4-6](#)
- [Route Plan Report, page 4-6](#)
- [Calling Search Space and Partitions, page 4-6](#)
- [Immediate Divert, page 4-6](#)
- [Barge, page 4-6](#)
- [Directed Call Park, page 4-7](#)
- [Q.SIG Intercluster Trunks, page 4-7](#)

Attendant Console

Cisco Unified Communications Manager Attendant Console uses the Call Park Retrieval Allowed check box (found on the Cisco Unified Communications Manager Administration User Configuration window) when configuring the ac user. See [“Configuring the ac Application User”](#) in the *Cisco Unified Communications Manager Features and Services Guide* for details.

CTI Applications

CTI applications (for example, Attendant Console) access call park functionality, including monitoring activity on call park DN. To monitor a call park DN, you must add an application or end user that is associated with the CTI application to the Standard CTI Allow Call Park Monitoring user group.

Refer to the [“Configuration Checklist for Cisco Unified Communications Manager Attendant Console” section on page 11-19](#) for details.

Music On Hold

Music on hold allows users to place calls on hold with music that a streaming source provides. Music on hold allows two types of hold:

- User hold—The system invokes this type of hold when a user presses the Hold button or Hold softkey.
- Network hold—This type of hold takes place when a user activates the transfer, conference, or call park feature, and the hold automatically gets invoked.

Route Plan Report

The route plan report displays the patterns and directory numbers that are configured in Cisco Unified Communications Manager. Use the route plan report to look for overlapping patterns and directory numbers before assigning a directory number to call park. Refer to the [Route Plan Report](#) chapter in the *Cisco Unified Communications Manager Administration Guide*.

Calling Search Space and Partitions

Assign the Call Park directory number or range to a partition to limit call park access to users on the basis of the device calling search space. See [Calling Search Space Configuration](#) and [Partition Configuration](#) in the *Cisco Unified Communications Manager Administration Guide*.

Immediate Divert

Call park supports Immediate Divert (iDivert softkey). For example, user A calls user B, and user B parks the call. User B retrieves the call and then decides to send the call to voice-messaging mailbox by pressing the iDivert softkey. User A receives the voice-messaging mailbox greeting of user B.

Barge

The following paragraphs describe the differences between Barge and cBarge with call park.

Barge with Call Park

The target phone (the phone that is being barged upon) controls the call. The barge initiator “piggy backs” on the target phone. The target phone includes most of the common features, even when the target is being barged; therefore, the barge initiator has no feature access. When the target parks a call, the barge initiator then must release its call (the barge).

cBarge with Call Park

The target and barge initiator act as peers. The cBarge feature uses a conference bridge, which makes it behave similar to a MeetMe conference. Both phones (target and barge initiator) have full access to their features.

Directed Call Park

Cisco recommends that you do not configure both directed call park and the Park softkey for call park, but the possibility exists to configure both. If you configure both, ensure that the call park and directed call park numbers do not overlap.

Q.SIG Intercluster Trunks

When a user parks a call across a QSIG intercluster trunk or a QSIG gateway trunk, the caller who has been parked (the parkee) does not see the To parked number message. The phone continues to display the original connected number. The call has been parked, and the user who parked the call can retrieve it. When the call is retrieved from the parked state, the call continues, but the caller who was parked does not see the newly connected number.

Additional Information

See the [“Related Topics”](#) section on page 4-24.

Restrictions

The following restrictions apply to call park:

- Cisco Unified Communications Manager can park only one call at each call park extension number.
- Ensure each call park directory number, partition, and range is unique within the Cisco Unified Communications Manager cluster.
- For shared line devices across nodes, the line will register to the node on which the device registers first. For example, if a device from subscriber2 registers first and the line is created in subscriber2 and the publisher server, the line belongs to subscriber2. Each node must be configured with the call park number.
- To achieve failover/fallback, configure call park numbers on the publisher server and subscriber nodes. With this configuration, when the primary node is down, the line/device association gets changed to the secondary node, and the secondary node call park number gets used.
- Each Cisco Unified Communications Manager to which devices are registered needs its own unique call park directory number and range.
- Cisco Unified IP Phone 7902 cannot park a call (retrieval of parked calls only).
- Cisco Unified Communications Manager Administration does not validate the call park numbers or range that you use to configure call park. To help identify invalid numbers or ranges and potential range overlaps, use the Cisco Unified Communications Manager Dialed Number Analyzer tool.
- If any call park numbers are configured for Cisco Unified Communications Manager on a node that is being deleted in the Server Configuration window (System > Server), the server deletion fails. Before you can delete the node, you must delete the call park numbers in Cisco Unified Communications Manager Administration.

- Cisco Unified Communications Manager Administration does not check that the value that is entered for Call Park Reversion Timer is less than the value that is entered for the Call Park Display Timer. If you entered a Call Park Reversion Timer value that is less than the Call Park Display Timer, call park numbers will not display on the phone.

See the [“Configuring a Call Park Number” section on page 4-11](#) for configuration details.

Additional Information

See the [“Related Topics” section on page 4-24](#).

Installing and Activating Call Park

Call park, a system feature, comes standard with Cisco Unified Communications Manager software. It does not require special installation.

Additional Information

See the [“Related Topics” section on page 4-24](#).

Configuring Call Park

This section contains the following information:

- [Call Park Configuration Checklist, page 4-8](#)
- [Setting the Service Parameters for Call Park, page 4-9](#)
- [Finding a Call Park Number, page 4-10](#)
- [Configuring a Call Park Number, page 4-11](#)
- [Deleting a Call Park Number, page 4-12](#)

Additional Information

See the [“Related Topics” section on page 4-24](#).

Call Park Configuration Checklist

[Table 4-1](#) provides a checklist to configure Call Park.

Table 4-1 Call Park Configuration Checklist

Configuration Steps		Related procedures and topics
Step 1	Configure a partition for call park extension numbers to make partition available only to users who have the partition in their calling search space.	Configuring a Partition , <i>Cisco Unified Communications Manager Administration Guide</i> Media Termination Point Configuration , <i>Cisco Unified Communications Manager Administration Guide</i>
Step 2	Configure a unique call park number or define a range of call park extension numbers for each Cisco Unified Communications Manager in the cluster.	Configuring a Call Park Number , page 4-11
Step 3	Add all servers that call park uses to the appropriate Cisco Unified Communications Manager group. Note Servers and Cisco Unified Communications Managers get configured during installation.	Cisco Unified Communications Manager Group Configuration , <i>Cisco Unified Communications Manager Administration Guide</i>
Step 4	Assign the Standard User softkey template to each device that has call park access. For phones that do not use softkeys, the phone button template with the Call Park button automatically gets configured.	Softkey Template Configuration , <i>Cisco Unified Communications Manager Administration Guide</i>
Step 5	In the User Group Configuration window, assign application and end users to the Standard CTI Allow Call Park Monitoring user group. This applies only to users associated with CTI applications requiring Call Park monitoring capability (for example, Attendant Console).	Adding Users to a User Group , <i>Cisco Unified Communications Manager Administration Guide</i>
Step 6	Notify users that the call park feature is available.	Refer to the phone documentation for instructions on how users access call park features on their Cisco Unified IP Phone.

Additional Information

See the [“Related Topics”](#) section on page 4-24.

Setting the Service Parameters for Call Park

Cisco Unified Communications Manager provides two clusterwide service parameters for call park: Call Park Display Timer and Call Park Reversion Timer. Each service parameter includes a default and requires no special configuration.

- **Call Park Display Timer**—Default specifies 10 seconds. This parameter determines how long a call park number displays on the phone that parked the call. Set this timer for each server in a cluster that has the Cisco CallManager service and call park configured.
- **Call Park Reversion Timer**—Default specifies 60 seconds. This parameter determines the time that a call remains parked. Set this timer for each server in a cluster that has the Cisco CallManager service and call park configured. When this timer expires, the parked call returns to the device that parked the call. If a hunt group member parks a call that comes through a hunt pilot, the call goes back to the hunt pilot upon expiration of the Call Park Reversion Timer.

**Note**

To set the timers, choose **System > Service Parameters** and update the Call Park Display Timer and the Call Park Reversion Timer fields in the **Clusterwide Parameters (Feature-General)** pane.

Additional Information

See the “[Related Topics](#)” section on page 4-24.

Finding a Call Park Number

Because you may have several call park numbers in your network, Cisco Unified Communications Manager lets you locate specific call park numbers on the basis of specific criteria. Use the following procedure to locate call park numbers.

**Note**

During your work in a browser session, Cisco Unified Communications Manager Administration retains your call park number search preferences. If you navigate to other menu items and return to this menu item, Cisco Unified Communications Manager Administration retains your call park number search preferences until you modify your search or close the browser.

Procedure

Step 1 Choose **Call Routing > Call Park**.

The Find and List Call Park Numbers window displays.

Step 2 To find all records in the database, ensure the dialog box is empty; go to [Step 3](#).

To filter or search records:

- From the first drop-down list box, select a search parameter.
- From the second drop-down list box, select a search pattern.
- Specify the appropriate search text, if applicable.

**Note**

To add additional search criteria click the + button. When you add criteria, the system searches for a record that matches all criteria that you specify. To remove criteria, click the – button to remove the last added criteria or click the **Clear Filter** button to remove all added search criteria.

Step 3 Click **Find**.

All or matching records display. You can change the number of items that display on each page by choosing a different value from the Rows per Page drop-down list box.

**Note**

You can delete multiple records from the database by checking the check boxes next to the appropriate record and clicking **Delete Selected**. You can delete all configurable records for this selection by clicking **Select All** and then clicking **Delete Selected**.

Step 4 From the list of records that display, click the link for the record that you want to view.

**Note**

To reverse the sort order, click the up or down arrow, if available, in the list header.

The window displays the item that you choose.

Additional Information

See the [“Related Topics” section on page 4-24](#).

Configuring a Call Park Number

This section describes how to add, copy, and update a single call park extension number or range of extension numbers.

Procedure

-
- Step 1** Choose **Call Routing > Call Park**.
- Step 2** Perform one of the following tasks:
- To add a new Call Park Number, click **Add New**.
 - To copy a Call Park Number, use the procedure in the [“Finding a Call Park Number” section on page 4-10](#) to locate the call park number or range of numbers. Click the Copy icon.
 - To update a Call Park Number, use the procedure in the [“Finding a Call Park Number” section on page 4-10](#) to locate the call park number or range of numbers.
- The Call Park Number Configuration window displays.
- Step 3** Enter or update the appropriate settings as described in [Table 4-2](#).
- Step 4** To save the new or changed call park numbers in the database, click **Save**.
-

Additional Information

See the [“Related Topics” section on page 4-24](#).

Call Park Configuration Settings

[Table 4-2](#) describes the call park configuration settings. For related procedures, see the [“Related Topics” section on page 4-24](#).

Table 4-2 Call Park Configuration Settings

Field	Description
Call Park Number/Range	<p>Enter the call park extension number. You can enter literal digits or the wildcard character X (the system allows one or two Xs). For example, enter 5555 to define a single call park extension number of 5555 or enter 55XX to define a range of call park extension numbers from 5500 to 5599.</p> <p>Note You can create a maximum of 100 call park numbers with one call park range definition. Make sure that the call park numbers are unique.</p> <p>Note You cannot overlap call park numbers between Cisco Unified Communications Manager servers. Ensure that each Cisco Unified Communications Manager server has its own number range.</p>
Description	Provide a brief description of this call park number.
Partition	<p>If you want to use a partition to restrict access to the call park numbers, choose the desired partition from the drop-down list box. If you do not want to restrict access to the call park numbers, choose <None> for the partition.</p> <p>See Searching for a Partition in the <i>Cisco Unified Communications Manager Administration Guide</i> for instructions on finding a partition when there are a large number of them configured.</p> <p>Note Make sure that the combination of call park extension number and partition is unique within the Cisco Unified Communications Manager cluster.</p>
Cisco Unified Communications Manager	<p>Using the drop-down list box, choose the Cisco Unified Communications Manager to which these call park numbers apply.</p> <p>Note You can create a maximum of 100 call park numbers with one call park range definition. Make sure that the call park numbers are unique.</p> <p>Note You cannot overlap call park numbers between Cisco Unified Communications Manager servers. Ensure that each Cisco Unified Communications Manager server has its own number range.</p>

Deleting a Call Park Number

This section describes how to delete call park numbers from the Cisco Unified Communications Manager database.

Procedure

- Step 1** Using the procedure in the [“Finding a Call Park Number”](#) section on page 4-10, locate the call park number or range of numbers.

Step 2 Click the call park number or range of numbers that you want to delete.

Step 3 Click **Delete**.



Note You can delete multiple call park numbers from the Find and List Call Park Numbers window by checking the check boxes next to the appropriate call park numbers and clicking **Delete Selected**. You can delete all call park numbers in the window by clicking **Select All** and then clicking **Delete Selected**.

Additional Information

See the “[Related Topics](#)” section on page 4-24.

Directed Call Park

Directed Call Park allows a user to transfer a call to an available user-selected directed call park number. Configure directed call park numbers in the Cisco Unified Communications Manager Directed Call Park Configuration window. Configured directed call park numbers exist clusterwide. You can configure phones that support the directed call park Busy Lamp Field (BLF) to monitor the busy/idle status of specific directed call park numbers. Users can also use the BLF to speed dial a directed call park number. See [Interactions and Restrictions](#), page 4-15, for a list of the phone models that support the BLF.

This chapter provides the following information about directed call park:

- [Introducing Directed Call Park](#), page 4-13
- [System Requirements for Directed Call Park](#), page 4-14
- [Interactions and Restrictions](#), page 4-15
- [Installing and Activating Directed Call Park](#), page 4-17
- [Directed Call Park Configuration Checklist](#), page 4-18
- [Setting the Service Parameters for Directed Call Park](#), page 4-20
- [Finding a Directed Call Park Number](#), page 4-20
- [Configuring a Directed Call Park Number](#), page 4-21
- [Directed Call Park Configuration Settings](#), page 4-22
- [Configuring BLF/Directed Call Park Buttons](#), page 4-22
- [BLF/Directed Call Park Configuration Settings](#), page 4-23
- [Deleting a Directed Call Park Number](#), page 4-24
- [Related Topics](#), page 4-24

Introducing Directed Call Park

Cisco Unified Communications Manager can park only one call at each directed call park number. To retrieve a parked call, a user must dial a configured retrieval prefix followed by the directed call park number at which the call is parked. Configure the retrieval prefix in the Directed Call Park Configuration window.

Example 1: Using the Directed Call Park Feature—Parked Call Gets Retrieved

The following example illustrates the use of the directed call park feature and retrieval of the parked call.

1. Users A1 and A2 connect in a call.
2. To park the call, A1 presses the Transfer softkey (or Transfer button, if available) and dials directed call park number 80 (for example) or presses the BLF button for directed call park number 80 (if the phone model supports the BLF button).
3. A1 either presses the Transfer softkey (or Transfer button) again or goes on hook to complete the directed call park transfer. This action parks A2 on directed call park number 80.



Note The user can complete the transfer only by going on hook rather than pressing the Transfer softkey (or Transfer button) a second time if the Transfer On-hook Enabled service parameter is set to True. See “[Onhook Call Transfer](#)” in the *Cisco Unified Communications Manager System Guide*.

4. From any phone with a correctly configured partition and calling search space, user B1 dials the directed call park prefix (21, for example) followed by the directed call park number 80 to retrieve the call. B1 connects to A2.

Example 2: Using the Directed Call Park Feature—Parked Call Does Not Get Retrieved

The following example illustrates the use of the directed call park feature when the parked call does not get retrieved and reverts to the reversion number.

1. Users A1 and A2 connect in a call.
2. To park the call, A1 presses the Transfer softkey (or Transfer button, if available) and dials directed call park number 80 (for example) or presses the BLF button for directed call park number 80 (if the phone model supports the BLF button).
3. A1 either presses the Transfer softkey (or Transfer button) again or goes on hook to complete the directed call park transfer. This action parks A2 on directed call park number 80.



Note The user can complete the transfer only by going on hook rather than pressing the Transfer softkey (or Transfer button) a second time if the Transfer On-hook Enabled service parameter is set to True. See “[Onhook Call Transfer](#)” in the *Cisco Unified Communications Manager System Guide*.

4. The call does not get retrieved before the Call Park Reversion Timer (service parameter) expires.
5. A2 reverts to the configured reversion number.

Additional Information

See the “[Related Topics](#)” section on page 4-24.

System Requirements for Directed Call Park

To operate, Directed Call Park requires the following software component:

- Cisco Unified Communications Manager

A user can park and retrieve a call by using directed call park from any phone that can perform a transfer including Cisco Unified IP Phones 7905, 7912, 7920, 7940, 7960, and 7970. Cisco VG248 Analog Phone Gateways also support directed call park.

The following phones that are running SCCP and phones that are running SIP support directed call park BLF:

- Cisco Unified IP Phones (7941, 7961, 7970, 7971)
- Cisco Unified IP Phone Expansion Module (7914, 7915, 7916)

The following phones that are running SCCP support directed call park BLF:

- Cisco Unified IP Phones (7905, 7912, 7920, 7940, 7960)

Additional Information

See the [“Related Topics” section on page 4-24](#).

Interactions and Restrictions

The following sections describe the interactions and restrictions for directed call park:

- [Interactions, page 4-15](#)
- [Restrictions, page 4-17](#)

Interactions

The following sections describe how directed call park interacts with Cisco Unified Communications Manager applications and call processing:

- [Attendant Console, page 4-15](#)
- [Music On Hold, page 4-15](#)
- [Route Plan Report, page 4-16](#)
- [Calling Search Space and Partitions, page 4-16](#)
- [Immediate Divert, page 4-16](#)
- [Barge, page 4-16](#)
- [Call Park, page 4-16](#)

Attendant Console

The Cisco Unified Communications Manager Administration End User Configuration window does not include any configuration or activation for directed call park as it does for call park. See [Restrictions, page 4-17](#), for additional information about directed call park with attendant console.

Music On Hold

Music on hold allows users to place calls on hold with music that is provided from a streaming source. Music on hold allows two types of hold:

- User hold—The system invokes this type of hold when a user presses the Hold button or Hold softkey.
- Network hold—This type of hold takes place when a user activates the transfer, conference, or call park feature, and the hold automatically gets invoked. This hold type applies to directed call park because directed call park is a transfer function.

Route Plan Report

The route plan report displays the patterns and directory numbers that are configured in Cisco Unified Communications Manager. Use the route plan report to look for overlapping patterns and directory numbers before assigning a directory number to directed call park. Refer to the [Route Plan Report](#) chapter in the *Cisco Unified Communications Manager Administration Guide*.

Calling Search Space and Partitions

Assign the directed call park directory number or range to a partition to limit directed call park access to users on the basis of the device calling search space. See [Calling Search Space Configuration](#) and [Partition Configuration](#) in the *Cisco Unified Communications Manager Administration Guide*.

Immediate Divert

Directed call park supports Immediate Divert (iDivert softkey). For example, user A calls user B, and user B parks the call. User B retrieves the call and then decides to send the call to voice-messaging mailbox by pressing the iDivert softkey. User A receives the voice-messaging mailbox greeting of user B.

Barge

The following paragraphs describe the differences between Barge and cBarge with directed call park.

Barge with Directed Call Park

The target phone (the phone that is being barged upon) controls the call. The barge initiator “piggy backs” on the target phone. The target phone includes most of the common features, even when the target is being barged; therefore, the barge initiator has no feature access. When the target parks a call by using directed call park, the barge initiator then must release its call (the barge).

cBarge with Directed Call Park

The target and barge initiator act as peers. The cBarge feature uses a conference bridge that makes it behave similar to a meet-me conference. Both phones (target and barge initiator) retain full access to their features.

Call Park

Cisco recommends that you do not configure both directed call park and the Park softkey for call park, but the possibility exists to configure both. If you configure both, ensure that the call park and directed call park numbers do not overlap.

A caller who has been parked (the parkee) by using the directed call park feature cannot, while parked, use the standard call park feature.

Restrictions

The following restrictions apply to directed call park:

- Cisco Unified Communications Manager can park only one call at each directed call park number.
- Ensure each directed call park directory number, partition, and range is unique within the Cisco Unified Communications Manager cluster. If the Park softkey is also activated (not recommended), ensure that no overlap exists between call park numbers and directed call park numbers.
- A caller who has been parked (the parkee) by using the directed call park feature cannot, while parked, use the standard call park feature.
- The directed call park BLF cannot monitor a range of directed call park numbers. A user can monitor only individual directed call park numbers by using the directed call park BLF. For example, if you configure a directed call park number range 8X, you cannot use the directed call park BLF to monitor that whole range of 80 to 89.
- Attendant console attendants must use the Consult Transfer button to send calls to a directed call park number. If they use the Transfer button, the system cannot revert the call to the attendant when the reversion timer expires, and the caller receives a reorder tone.
- You cannot delete a directed call park number that a device is configured to monitor (using the BLF button). A message indicates that the directed call park number or range cannot be deleted because it is in use. To determine which devices are using the number, click the Dependency Records link on the Directed Call Park Configuration window.
- If reversion number is not configured, the call reverts to the parker (parking party) after the call park reversion timer expires. Directed Call Park for phones that are running SIP is designed as busy lamp field (BLF) plus call transfer (to a park code). The transfer functionality remains the same as for phones that are running SCCP. The following limitations apply to directed call park for phones that are running SIP:
 - Directed call park gets invoked by using the transfer softkey on Cisco Unified IP Phones 7940 and 7960 that are running SIP.
 - The system does not support directed call park when the blind transfer softkey is used on Cisco Unified IP Phones 7940 and 7960 that are running SIP.
 - The system does not support directed call park BLF on Cisco Unified IP Phones 7940 and 7960 that are running SIP, and third-party phones that are running SIP.
 - The following Cisco Unified IP Phones that are running SIP support directed call park BLF: 7941, 7961, 7970, and 7971.

See the [“Configuring a Directed Call Park Number”](#) section on page 4-21 for configuration details.

Additional Information

See the [“Related Topics”](#) section on page 4-24.

Installing and Activating Directed Call Park

Directed call park system feature comes standard with Cisco Unified Communications Manager software. Any phone that can perform a transfer can use directed call park. It does not require special installation. Cisco recommends that you configure either call park or directed call park, but not both. If you do configure both, ensure that the directed call park and call park numbers do not overlap.

Additional Information

See the “Related Topics” section on page 4-24.

Configuring Directed Call Park

This section contains the following information:

- [Directed Call Park Configuration Checklist, page 4-18](#)
- [Setting the Service Parameters for Directed Call Park, page 4-20](#)
- [Finding a Directed Call Park Number, page 4-20](#)
- [Configuring a Directed Call Park Number, page 4-21](#)
- [Directed Call Park Configuration Settings, page 4-22](#)
- [Configuring BLF/Directed Call Park Buttons, page 4-22](#)
- [BLF/Directed Call Park Configuration Settings, page 4-23](#)
- [Deleting a Directed Call Park Number, page 4-24](#)

Directed Call Park Configuration Checklist

[Table 4-3](#) provides a checklist to configure directed call park.

Table 4-3 Directed Call Park Configuration Checklist

Configuration Steps	Related procedures and topics
<p>Step 1 Configure a partition for directed call park numbers to make the partition available only to users who have the partition in their calling search space. To successfully retrieve a parked call, the calling search space from which the user is retrieving the call must contain the partition that includes the directed call park number.</p>	<p>Configuring a Partition, <i>Cisco Unified Communications Manager Administration Guide</i></p> <p>Media Termination Point Configuration, <i>Cisco Unified Communications Manager Administration Guide</i></p> <p>Calling Search Space Configuration, <i>Cisco Unified Communications Manager Administration Guide</i></p>
<p>Step 2 Configure a unique directed call park number or define a range of directed call park numbers. You must specify a range by using wildcards. For example, the range 40XX configures the range as 4000 to 4099.</p> <p> Caution Do not enter a range by using dashes (such as 4000-4040).</p> <p>Note You can monitor only individual directed call park numbers with the directed call park BLF. If you configure a range of numbers, the BLF cannot support monitoring of the busy/idle status of the range or of any number within the range.</p>	<p>Configuring a Directed Call Park Number, page 4-21</p>
<p>Step 3 Assign the Standard User softkey template to each device that has directed call park access. For phones that do not use softkeys, the phone button template with the Transfer button automatically gets configured.</p>	<p>Softkey Template Configuration, <i>Cisco Unified Communications Manager Administration Guide</i></p>
<p>Step 4 For phone models that support the directed call park BLF, configure the phone button template to include one or more Call Park BLF buttons and configure the directed call park BLF settings.</p>	<p>Guidelines for Customizing Phone Button Templates, <i>Cisco Unified Communications Manager System Guide</i></p> <p>Configuring BLF/Directed Call Park Buttons</p>
<p>Step 5 Notify users that the directed call park feature is available.</p>	<p>Refer to the phone documentation for instructions on how users access directed call park features on their Cisco Unified IP Phone.</p>

Additional Information

See the [“Related Topics”](#) section on page 4-24.

Setting the Service Parameters for Directed Call Park

The Call Park Reversion Timer clusterwide service parameter affects directed call park. This parameter determines the time that a call remains parked. The default specifies 60 seconds. When the timer expires, the parked call returns to either the device that parked the call or to another specified number, depending on what you configure in the Directed Call Park Configuration window.

Additional Information

See the “[Related Topics](#)” section on page 4-24.

Finding a Directed Call Park Number

Because you may have several directed call park numbers in your network, Cisco Unified Communications Manager lets you locate specific directed call park numbers on the basis of specific criteria. Use the following procedure to locate directed call park numbers.



Note

During your work in a browser session, Cisco Unified Communications Manager Administration retains your directed call park number search preferences. If you navigate to other menu items and return to this menu item, Cisco Unified Communications Manager Administration retains your directed call park number search preferences until you modify your search or close the browser.

Procedure

Step 1 Choose **Call Routing > Directed Call Park**.

The Find and List Directed Call Park Numbers window displays.

Step 2 To find all records in the database, ensure the dialog box is empty; go to [Step 3](#).

To filter or search records:

- From the first drop-down list box, select a search parameter.
- From the second drop-down list box, select a search pattern.
- Specify the appropriate search text, if applicable.



Note

To add additional search criteria, click the + button. When you add criteria, the system searches for a record that matches all criteria that you specify. To remove criteria, click the – button to remove the last added criteria or click the **Clear Filter** button to remove all added search criteria.

Step 3 Click **Find**.

All or matching records display. You can change the number of items that display on each page by choosing a different value from the Rows per Page drop-down list box.



Note

You can delete multiple records from the database by checking the check boxes next to the appropriate record and clicking **Delete Selected**. You can delete all configurable records for this selection by clicking **Select All** and then clicking **Delete Selected**.

Step 4 From the list of records that display, click the link for the record that you want to view.



Note To reverse the sort order, click the up or down arrow, if available, in the list header.

The window displays the item that you choose.

Additional Information

See the [“Related Topics” section on page 4-24](#).

Configuring a Directed Call Park Number

This section describes how to add, copy, and update a single directed call park extension number or range of extension numbers.

Procedure

Step 1 Choose **Call Routing > Directed Call Park**.

Step 2 Perform one of the following tasks:

- To add a new Directed Call Park Number, click **Add New**.
- To copy a Directed Call Park Number, use the procedure in the [“Finding a Directed Call Park Number” section on page 4-20](#) to locate the directed call park number or range of numbers. Click the Copy icon.
- To update a Directed Call Park Number, use the procedure in the [“Finding a Directed Call Park Number” section on page 4-20](#) to locate the directed call park number or range of numbers.

The Directed Call Park Number Configuration window displays.

Step 3 Enter or update the appropriate settings as described in [Table 4-4](#).

Step 4 To save the new or changed call park numbers in the database, click **Save**.



Note Updating a directed call park number causes Cisco Unified Communications Manager to immediately revert any call that is parked on that number. This occurs because, when you update a directed call park number, Cisco Unified Communications Manager actually deletes the old information and then adds the new information. At the point that the old information is deleted, a parked call on that number cannot remain parked or be retrieved in the usual way and must be reverted.



Note Whenever changes are made to directed call park numbers or ranges, any devices that are configured to monitor those directed call park numbers by using the BLF must restart to correct the display. Change notification automatically restarts impacted devices when it detects directed call park number changes. You can also use the Restart Devices button on the Directed Call Park Configuration window.

Additional Information

See the [“Related Topics” section on page 4-24](#).

Directed Call Park Configuration Settings

Table 4-4 describes the directed call park configuration settings.

Table 4-4 Directed Call Park Configuration Settings

Field	Description
Number	Enter the directed call park number. You can enter literal digits or the wildcard character X (the system allows one or two Xs). For example, enter 5555 to define a single call park number of 5555 or enter 55XX to define a range of directed call park extension numbers from 5500 to 5599. Make sure that the directed call park numbers are unique and that they do not overlap with call park numbers.
Description	Provide a brief description of this directed call park number or range.
Partition	<p>If you want to use a partition to restrict access to the directed call park numbers, choose the desired partition from the drop-down list box. If you do not want to restrict access to the directed call park numbers, leave the partition as the default of <None>.</p> <p>See Searching for a Partition in the <i>Cisco Unified Communications Manager Administration Guide</i> for instructions on finding a partition when there are a large number of them configured.</p> <p>Note Make sure that the combination of directed call park number and partition is unique within the Cisco Unified Communications Manager cluster.</p>
Reversion Number	<p>Enter the number to which you want the parked call to return if not retrieved, or leave the field blank.</p> <p>Note A reversion number can comprise digits only; you cannot use wildcards.</p>
Reversion Calling Search Space	Using the drop-down list box, choose the calling search space or leave the calling search space as the default of <None>.
Retrieval Prefix	For this required field, enter the prefix for retrieving a parked call. The system needs the retrieval prefix to distinguish between an attempt to retrieve a parked call and an attempt to initiate a directed park.



Note

Whenever changes are made to directed call park numbers, any devices that are configured to monitor those directed call park numbers by using the directed call BLF must restart to correct the display. Change notification automatically restarts impacted devices when it detects directed call park number changes. You also can use the Restart Devices button on the Directed Call Park Configuration window.

Additional Information

See the [“Related Topics”](#) section on page 4-24.

Configuring BLF/Directed Call Park Buttons

To configure BLF/Directed Call Park buttons, perform the following procedure:

Procedure

- Step 1** To configure the BLF/Directed Call Park button in the Phone Configuration window, find the phone, as described in the “[Cisco Unified IP Phone Configuration](#)” chapter in the *Cisco Unified Communications Manager Administration Guide*.
- Step 2** To configure the BLF/Directed Call Park button for user device profiles, find the user device profile as described in the “[Device Profile Configuration](#)” chapter in the *Cisco Unified Communications Manager Administration Guide*.
- Step 3** After the configuration window displays, click the **Add a new BLF Directed Call Park** link in the Association Information pane.



Tip The link does not display in the Association Information pane if the phone button template that you applied to the phone or device profile does not support BLF/Directed Call Park.

- Step 4** Configure the settings, as described in [Table 4-5](#).
- Step 5** After you complete the configuration, click **Save** and close the window.
- The directory number(s) display in the Association Information pane of the Phone Configuration Window.

Additional Information

See the “[Related Topics](#)” section on page 4-24.

BLF/Directed Call Park Configuration Settings

[Table 4-5](#) describes the settings that you configure for BLF/Directed Call Park buttons.

Table 4-5 *BLF/Directed Call Park Button Configuration Settings*

Field	Description
Directory Number	<p>The Directory Number drop-down list box displays a list of directory numbers that exist in the Cisco Unified Communications Manager database.</p> <p>For phones that are running SCCP or phones that are running SIP, choose the number (and corresponding partition, if it displays) that you want the system to dial when the user presses the speed-dial button; for example, 6002 in 3. Directory numbers that display without specific partitions belong to the default partition.</p>
Label	<p>Enter the text that you want to display for the BLF/Directed Call Park button.</p> <p>This field supports internationalization. If your phone does not support internationalization, the system uses the text that displays in the Label ASCII field.</p>

Table 4-5 *BLF/Directed Call Park Button Configuration Settings (continued)*

Field	Description
Label ASCII	<p>Enter the text that you want to display for the BLF/Directed Call Park button.</p> <p>The ASCII label represents the noninternationalized version of the text that you enter in the Label field. If the phone does not support internationalization, the system uses the text that displays in this field.</p> <p>Tip If you enter text in the Label ASCII field that differs from the text in the Label field, Cisco Unified Communications Manager Administration accepts the configuration for both fields, even though the text differs.</p>

Deleting a Directed Call Park Number

This section describes how to delete directed call park numbers from the Cisco Unified Communications Manager database.

Procedure

-
- Step 1** Using the procedure in the [“Finding a Directed Call Park Number”](#) section on page 4-20, locate the directed call park number or range of numbers.
- Step 2** Click the directed call park number or range of numbers that you want to delete.
- Step 3** Click **Delete**.
-



Note

Deleting a directed call park number causes Cisco Unified Communications Manager to immediately revert any call that is parked on that number. This occurs because, when the number is deleted, a parked call on that number cannot remain parked or be retrieved in the usual way and must be reverted.



Note

You cannot delete a directed call park number that a device is configured to monitor (using the BLF button). A message indicates that the directed call park number cannot be deleted because it is in use. To determine which devices are using the number, click the Dependency Records link in the Directed Call Park Configuration window.

Additional Information

See the [“Related Topics”](#) section on page 4-24.

Related Topics

- [Call Park and Directed Call Park, page 4-1](#)
- [Configuring a Call Park Number, page 4-11](#)

- [Finding a Call Park Number](#), page 4-10
- [Deleting a Call Park Number](#), page 4-12
- [Configuring Directed Call Park](#), page 4-18
- [Finding a Directed Call Park Number](#), page 4-20
- [Configuring BLF/Directed Call Park Buttons](#), page 4-22
- [Deleting a Directed Call Park Number](#), page 4-24
- [Phone Button Template Configuration](#), *Cisco Unified Communications Manager Administration Guide*
- [Cisco Unified IP Phone Configuration](#), *Cisco Unified Communications Manager Administration Guide*
- [Partition Configuration](#), *Cisco Unified Communications Manager Administration Guide*
- [Media Termination Point Configuration](#), *Cisco Unified Communications Manager Administration Guide*
- [Route Plan Report](#), *Cisco Unified Communications Manager Administration Guide*
- [Softkey Template Configuration](#), *Cisco Unified Communications Manager Administration Guide*
- [End User Configuration](#), *Cisco Unified Communications Manager Administration Guide*
- [User Group Configuration](#), *Cisco Unified Communications Manager Administration Guide*
- [Clustering](#), *Cisco Unified Communications Manager System Guide*
- *Cisco Unified IP Phone Administration Guide for Cisco Unified Communications Manager*
- Cisco Unified IP Phone user documentation and release notes (all models)

