



CHAPTER 9

Cisco Unified Communications Manager Assistant With Proxy Line Support

The Cisco Unified Communications Manager Assistant feature enables managers and their assistants to work together more effectively. Cisco Unified Communications Manager Assistant supports two modes of operation: proxy line support and shared line support. The Cisco IP Manager Assistant service supports both proxy line and shared line support simultaneously in a cluster. For information about Cisco Unified Communications Manager Assistant with shared line support, see the [“Cisco Unified Communications Manager Assistant With Shared Line Support”](#) section on page 10-1.

Cisco Unified Communications Manager Assistant supports up to 3500 managers and 3500 assistants. To accommodate this number of users, the administrator configures up to three Cisco Unified Communications Manager Assistant applications in one Cisco Unified Communications Manager cluster and assigns managers and assistants to each instance of the application.

The feature comprises a call-routing service, enhancements to phone capabilities for the manager and the assistant, and assistant console interfaces that are primarily used by the assistant.

The service intercepts calls that are made to managers and routes them to selected assistants, to managers, or to other targets on the basis of preconfigured call filters. The manager can change the call routing dynamically; for example, by pressing a softkey on the phone, the manager can instruct the service to route all calls to the assistant and can receive status on these calls.

Cisco Unified Communications Manager Assistant users comprise managers and assistants. The routing service intercepts manager calls and routes them appropriately. An assistant user handles calls on behalf of a manager.

This chapter provides the following information about Cisco Unified Communications Manager Assistant:

- [Introducing Cisco Unified Communications Manager Assistant, page 9-2](#)
- [System Requirements for Cisco Unified Communications Manager Assistant with Proxy Line Support, page 9-7](#)
- [Interactions and Restrictions, page 9-7](#)
- [Installing and Activating Cisco Unified Communications Manager Assistant, page 9-11](#)
- [Configuring Cisco Unified Communications Manager Assistant with Proxy Line Support, page 9-12](#)
- [Providing Information to Cisco Unified Communications Manager Assistant Managers and Assistants, page 9-39](#)
- [Related Topics, page 9-42](#)

Introducing Cisco Unified Communications Manager Assistant

The following sections provide information about the Cisco Unified Communications Manager Assistant feature:

- [Cisco Unified Communications Manager Assistant Architecture Overview, page 9-2](#)
- [Cisco Unified Communications Manager Assistant Database Access Architecture, page 9-5](#)
- [Manager Interfaces, page 9-5](#)
- [Assistant Interfaces, page 9-6](#)
- [Softkeys, page 9-6](#)
- [Cisco Unified Communications Manager Assistant Administration Interface, page 9-6](#)

Cisco Unified Communications Manager Assistant Architecture Overview

The Cisco Unified Communications Manager Assistant feature architecture comprises the Cisco IP Manager Assistant service, the assistant console interfaces, and the Cisco Unified IP Phone interfaces. See [Figure 9-1](#).

Cisco IP Manager Assistant service routes calls that are presented to a CTI route point that is defined in the Cisco IP Manager Assistant service parameters. See the [“Setting the Service Parameters for Cisco Unified Communications Manager Assistant”](#) section on page 9-22.

Additional Information

See the [“Related Topics”](#) section on page 9-42.

Figure 9-1 Cisco Unified Communications Manager Assistant Architecture

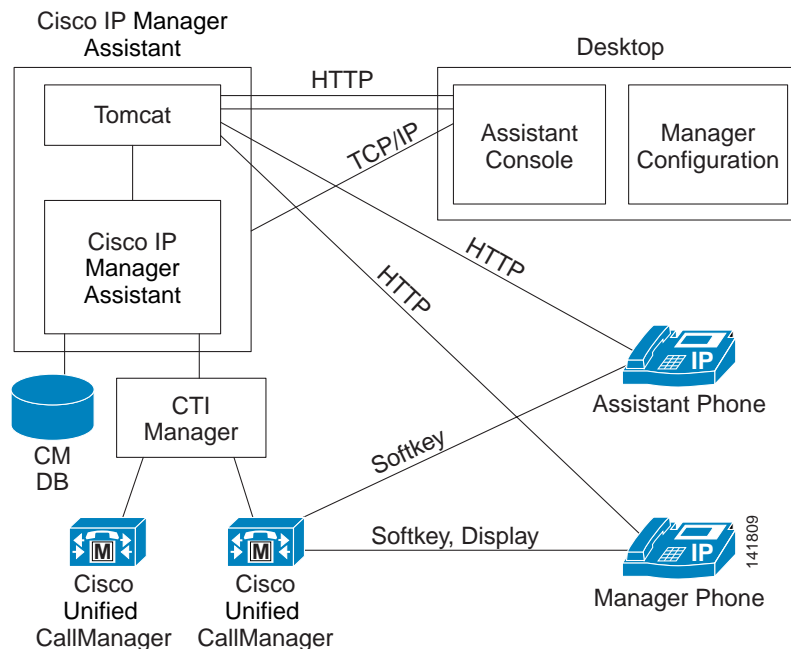

Cisco IP Manager Assistant Service

Cisco Tomcat loads the Cisco IP Manager Assistant service, a servlet. Cisco Tomcat gets installed at Cisco Unified Communications Manager installation.

The Cisco IP Manager Assistant service gets installed on all Cisco Unified Communications Manager servers in a cluster. After installation, the administrator activates the service from Serviceability, which automatically starts Cisco Unified Communications Manager Assistant. The Cisco IP Manager Assistant service checks to see whether it is one of the Cisco Unified Communications Manager Assistant servers that is configured in the clusterwide service parameter, Cisco IPMA Server (Primary) IP Address. If it is, the Cisco IP Manager Assistant service attempts to become the active Cisco IP Manager Assistant service. Currently, a Cisco Unified Communications Manager cluster supports only one active Cisco IP Manager Assistant service.

The Cisco IP Manager Assistant service performs the following tasks:

- Hosts the HTTP services that run on the manager phone.
- Hosts the web pages that the manager uses for configuration.
- Contains the routing logic that applies filters on an incoming call for a manager. See [Figure 9-2](#).
- Communicates to a Cisco Unified Communications Manager cluster through the Cisco CTIManager for third-party call control. Cisco Unified Communications Manager Assistant requires only one CTI connection for all users in a cluster.
- Accesses data from the database.
- Supports the Assistant Console application.

Cisco Unified Communications Manager supports redundancy of the Cisco IP Manager Assistant service. To achieve redundancy, you must configure a second Cisco IP Manager Assistant service in the same cluster.

Figure 9-2 Cisco Unified Communications Manager Assistant Routing Logic for Proxy Line Support

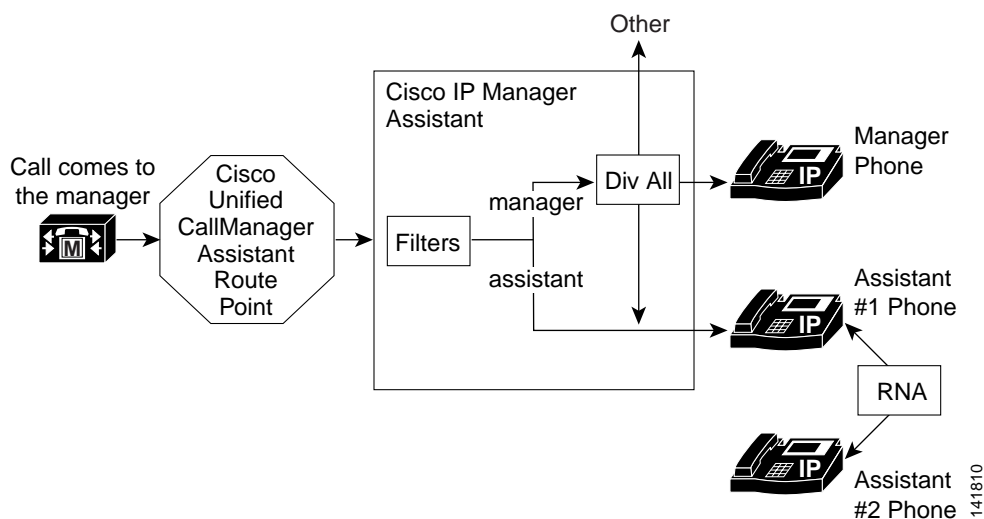

Cisco Unified Communications Manager Assistant implements redundancy by using an active/standby server model. At any time, only one Cisco Unified Communications Manager Assistant server remains active and servicing all assistant console applications and phones. The other server stays in a standby

mode and will detect failures on the active server. When it detects a failure, the backup server takes over and becomes the active server. All connections that were active get restored on the new server, and service continues uninterrupted to the users.

If the active server fails, the Assistant Console application fails over automatically to the backup server. The Cisco IPMA Assistant Console Heartbeat Interval service parameter (see the [“Setting the Service Parameters for Cisco Unified Communications Manager Assistant”](#) section on page 9-22) determines the time that the application takes to detect failure. A shorter heartbeat interval leads to faster failover. See [Figure 9-3](#).

Figure 9-3 Cisco Unified Communications Manager Assistant Redundancy

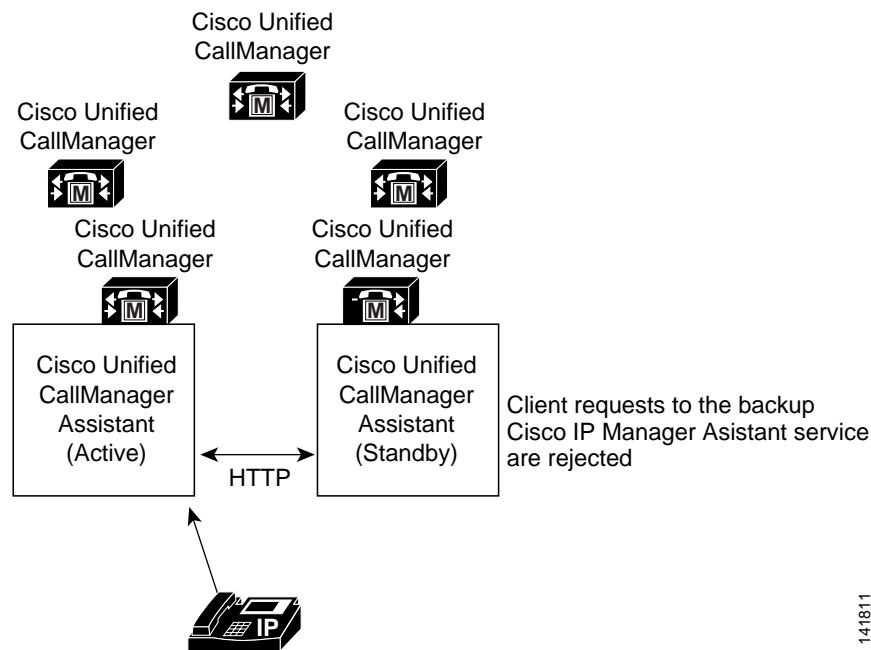

The Cisco IP Manager Assistant service includes built-in security to help prevent unauthorized access to its services. The user ID and password that are collected at the assistant console get encrypted before they are sent over the network. The Assistant Console blocks nonauthorized users who are posing as assistants.

Assistant Console Interface

Cisco Unified Communications Manager Assistant supports the following assistant console interfaces for managers and assistants:

- Assistant Console (used for call control, log on, assistant preferences, monitoring managers call activity, keyboard shortcuts)
- Manager configuration (used to configure send all calls target, immediate divert target, and filters)

Administrators use Cisco Unified Communications Manager Administration, End User Configuration, to configure Cisco Unified Communications Manager Assistant for managers and assistants. See [“Cisco Unified Communications Manager Assistant Administration Interface”](#) section on page 9-6.

Cisco Unified Communications Manager makes all Cisco Unified Communications Manager Assistant manager features available through the Cisco Unified IP Phone, except manager configuration, which is available by using a browser. Assistants use the Cisco Unified IP Phone and the assistant console application. See [“Manager Interfaces” section on page 9-5](#) and [“Assistant Interfaces” section on page 9-6](#).

For more information about how to use the Cisco Unified Communications Manager Assistant features, refer to the *Cisco Unified Communications Manager Assistant User Guide*.

Cisco Unified IP Phone Interface

Managers and assistants use softkeys and the Cisco Unified IP Phone Services button to access the Cisco Unified Communications Manager Assistant features. For more information about how to use the Cisco Unified Communications Manager Assistant phone features, refer to the *Cisco Unified Communications Manager Assistant User Guide*.

See [“Manager Interfaces” section on page 9-5](#) and [“Assistant Interfaces” section on page 9-6](#).

Cisco Unified Communications Manager Assistant Database Access Architecture

The database stores all Cisco Unified Communications Manager Assistant configuration information. When the manager or assistant logs in, the Cisco IP Manager Assistant service retrieves all data that is related to the manager or assistant from the database and stores it in memory.

Manager Interfaces

The manager phone makes all manager features available with the exception of Manager Configuration. Cisco Unified Communications Manager Assistant automatically logs in a manager when the Cisco IP Manager Assistant service starts.

The manager can change selected assistants by using the Cisco Unified IP Phone Services button.

The manager accesses the Cisco Unified Communications Manager Assistant features Assistant Watch, Intercept Call, and Transfer to Voice Mail from the Cisco Unified IP Phone softkeys.



Note

Managers also have access to Cisco Unified Communications Manager features such as Do Not Disturb and i-Divert.

The state of the features Assistant Watch, Do Not Disturb, Divert All Calls, and Filtering displays in the Status Window on the Cisco Unified IP Phone.

You can enable filtering and choose filter mode by using the Cisco Unified IP Phone Services button. Configuration of the filters occurs by using Manager Configuration. You can access the Manager Configuration on the assistant console by using a web browser (see the [“Manager Configuration” section on page 9-41](#)).

Refer to the *Cisco Unified Communications Manager Assistant User Guide* for more information.

Assistant Interfaces

The assistant accesses the Cisco Unified Communications Manager Assistant features by using the Assistant Console application and the Cisco Unified IP Phone. The Assistant Console, an application, provides call-control functions such as answer, divert, transfer, and hold. The assistant uses the Assistant Console to log on and log off, to set up assistant preferences, and to display the manager configuration window that is used to configure manager preferences.

The Assistant Console displays the assistant lines and the manager proxy lines. A proxy line specifies a phone line that appears on the assistant Cisco Unified IP Phone. Assistants use the proxy lines to manage calls that are intended for a manager. For more information on setting up proxy lines, see the [“Configuring Proxy, Incoming Intercom, and Primary Lines for the Assistant”](#) section on page 9-35.

When the assistant logs in from the Assistant Console, the softkeys Redirect and Transfer to Voice Mail become active for the proxy lines. Refer to the *Cisco Unified Communications Manager Assistant User Guide* for more information.

Softkeys

The Cisco Unified Communications Manager Assistant feature supports softkeys such as Redirect, Transfer to Voice Mail, and Do Not Disturb on the Cisco Unified IP Phone. Softkeys appear in their appropriate call state; for example, Transfer to Voice Mail does not appear if no active calls exist.

Cisco Unified Communications Manager Assistant supports the following softkey templates:

- Standard Manager—Supports manager for proxy mode
- Standard Shared Mode Manager—Supports manager for shared mode
- Standard Assistant—Supports assistant in proxy or shared mode

Additionally, the system makes call-processing (such as hold and dial) softkeys available with the Standard User template. The administrator configures the appropriate softkey template for the devices that managers and assistants use.



Note

The default process assigns call-processing softkey templates to devices.

Administrators can create custom softkey templates in addition to using the standard softkey templates that are included in Cisco Unified Communications Manager. Use Softkey Template configuration in Cisco Unified Communications Manager Administration to associate softkey templates with Cisco Unified Communications Manager Assistant devices and to create custom softkey templates. See [Softkey Template Configuration](#) in the *Cisco Unified Communications Manager Administration Guide*.

Cisco Unified Communications Manager Assistant Administration Interface

The administrator uses the End User Configuration window in Cisco Unified Communications Manager Administration to configure the manager and assistant. The administrator chooses the device for the manager and assistant, configures an intercom line for the manager and assistant, and assigns a proxy line for a manager on the assistant phone.

See the [“Manager and Assistant Configuration”](#) section on page 9-31.

System Requirements for Cisco Unified Communications Manager Assistant with Proxy Line Support

Cisco Unified Communications Manager Assistant with proxy line support requires the following software components to operate:

- Cisco Unified Communications Manager
- Microsoft Internet Explorer or Netscape Navigator:
 - Cisco Unified Communications Manager Assistant administration (using Cisco Unified Communications Manager Administration) supports Microsoft Internet Explorer (IE) 6, Internet Explorer 7, and Netscape 7.1.
 - The Assistant Console application installation program supports Microsoft Internet Explorer (IE) 6, Internet Explorer 7, and Netscape 7.1. (See the [“Interactions and Restrictions”](#) section on page 9-7 for more information.)
 - The Assistant Console application supports Microsoft Windows 2000, Microsoft Windows XP, or Windows Vista.
 - The Manager Configuration application supports Microsoft Internet Explorer (IE) 6 and Internet Explorer 7.
- Cisco Unified Communications Manager Bulk Administration Tool (BAT) if bulk adding of managers and assistants is planned.

The following phones that are running SCCP support Cisco Unified Communications Manager Assistant:

- Cisco Unified IP Phone 7970/71
- Cisco Unified IP Phone 7960/61
- Cisco Unified IP Phone 7940/41 (see the [“Restrictions”](#) section on page 9-11)

**Note**

Cisco Unified IP Phone 7960/61 and 7970/71 that are running Cisco Unified Communications Manager Assistant may be equipped with a Cisco Unified IP Phone Expansion Module 7914.

The following phones that are running SIP support Cisco Unified Communications Manager Assistant:

- Cisco Unified IP Phone 7970/71 (G and G-GE)
- Cisco Unified IP Phone 7941/61 (G and G-GE)

Because Cisco Unified Communications Manager Assistant is installed automatically on the same server with Cisco Unified Communications Manager, you do not require an additional server.

Interactions and Restrictions

The following sections describe the interactions and restrictions for Cisco Unified Communications Manager Assistant with proxy line support.

- [Interactions, page 9-8](#)
- [Restrictions, page 9-11](#)

Interactions

The following sections describe how Cisco Unified Communications Manager Assistant with proxy line support interacts with Cisco Unified Communications Manager applications and call processing:

- [Bulk Administration Tool, page 9-8](#)
- [Extension Mobility, page 9-8](#)
- [Reporting Tools, page 9-8](#)
- [Multilevel Precedence and Preemption \(MLPP\), page 9-10](#)
- [Time-of-Day Routing, page 9-10](#)
- [Message Waiting Indicator, page 9-10](#)
- [Intercom, page 9-10](#)

Bulk Administration Tool

The administrator can use the Bulk Administration Tool (BAT) to add many users (managers and assistants) at once instead of adding users individually. Refer to the *Cisco Unified Communications Manager Bulk Administration Guide* for more information.

The BAT templates that are created by the Cisco Unified Communications Manager Assistant Configuration Wizard for Cisco Unified IP Phones 7970, 7971, 7961, 7941 support only the Cisco Unified Communications Manager intercom lines.

Additional Information

See the “[Related Topics](#)” section on page 9-42.

Extension Mobility

A manager who uses the Cisco Extension Mobility feature can simultaneously use Cisco Unified Communications Manager Assistant. The manager logs into the Cisco Unified IP Phone by using extension mobility, and Cisco Unified Communications Manager Assistant service then automatically gets enabled on that phone. The manager can then access the Cisco Unified Communications Manager Assistant features.

To have access to Cisco Extension Mobility with Cisco Unified Communications Manager Assistant, the administrator checks the Mobile Manager check box in the Manager Configuration window in Cisco Unified Communications Manager Administration (which is accessed from the End User Configuration window). See the “[Configuring a Manager and Assigning an Assistant for Proxy Line Mode](#)” section on page 9-32. For more information about configuring device profiles, see [Configuring a Device Profile](#) in the *Cisco Unified Communications Manager Administration Guide*. For more information about Cisco Unified Communications Manager Extension Mobility, see [Chapter 8, “Cisco Extension Mobility.”](#)

Reporting Tools

Cisco Unified Communications Manager Assistant provides statistical information in the CDR Analysis and Reporting (CAR) tool and provides a summary of changes to configurations in a change log. The following sections describe these reporting tools.

CDR Analysis and Reporting

Cisco Unified Communications Manager Assistant supports call-completion statistics for managers and assistants and inventory reporting for managers and assistants. The CDR Analysis and Reporting (CAR) tool supports call-completion statistics. Cisco Unified Serviceability supports inventory reporting. Refer to the *Cisco Unified Serviceability Administration Guide* and the *CDR Analysis and Reporting Administration Guide* for more information.

IPMA_ChangeLog

The administrator can view a summary of changes that are made to the Manager or Assistant Configurations. A manager can change defaults by accessing the Manager Configuration from a URL. An assistant can change the manager defaults from the Assistant Console.



Note

Refer to the *Cisco Unified Communications Manager Assistant User Guide* for information about the URL and Manager Configuration.

When changes are made, the information gets sent to a log file that is called ipma_changeLogxxx.log. The log file resides on the server that runs the Cisco IP Manager Assistant service at the following location:

```
file get activelog tomcat/logs/ipma/log4j
```

The administrator can download this file from the server by using the Trace Collection Tool in the Cisco Unified Cisco Unified Real-Time Monitoring Tool. Refer to the *Cisco Unified Real-Time Monitoring Tool Administration Guide* for more information.

The log file contains the following fields:

- LineNumber—The line in the log file with information about changes
- TimeStamp—The time that the configuration changed
- for Manager/Assistant—Designation of whether the change is for the manager or the assistant
- for Userid—The userid of the manager or assistant that is being changed
- by Manager/Assistant—Designation of whether the manager or the assistant made the change
- by Userid—The userid of the manager or assistant who made the change
- Parameter Name—What changed; for example, divert target number
- Old Value—The value of the information before the change
- New Value—The value of the information after the change

Because the information in the log file is comma delimited, the administrator can open the log file by using a spreadsheet application such as Microsoft Excel. Use the following procedure to save the log file contents to the Microsoft Excel application.

Procedure

- Step 1** Start the Microsoft Excel application.
- Step 2** To open the ConfigChange*.log file, choose **File > Open**.
- Step 3** Choose the Original data type, file type as Delimited, and click **Next**.

- Step 4** Choose Delimiters as Comma and click **Next**.
- Step 5** When complete, click **Finish**.
-

Multilevel Precedence and Preemption (MLPP)

The following points describe the interactions between Cisco Unified Communications Manager Assistant with proxy line support and MLPP:

- Cisco Unified Communications Manager Assistant preserves call precedence in the handling of calls. For example, when an assistant diverts a call to a manager, Cisco Unified Communications Manager Assistant preserves the precedence of the call.
- Filtering of precedence calls occurs in the same manner as all other calls. The precedence of a call will not affect whether a call is filtered.
- Because Cisco Unified Communications Manager Assistant does not perceive the precedence of a call, it does not provide any additional indication of the precedence of a call on the assistant console.

Time-of-Day Routing

Time-of-Day routing routes calls to different locations based on the time that the call gets made; for example, during business hours, calls get routed to a manager office, and after hours, the calls go directly to voice-messaging service.

Partitions specify the time schedule and time zone that Time-of-Day routing uses. Cisco Unified Communications Manager Assistant partitions and partitions in Cisco Unified Communications Manager Assistant calling search spaces support Time-of-Day routing.

For more information about Time-of-Day routing, see [Time-of-Day Routing](#) in the *Cisco Unified Communications Manager System Guide*.

Message Waiting Indicator

The Message Waiting Indicator (MWI) on and off numbers should have the partition of the manager line in their calling search space. The partition can exist in any order of priority within each calling search space. For more information on configuring message waiting indicators, see [Configuring Message Waiting](#) in the *Cisco Unified Communications Manager Administration Guide*.

Intercom

Cisco Unified Communications Manager Assistant supports the following intercom features:

- Cisco Unified Communications Manager Assistant intercom (used with Cisco Unified IP Phones 7940 and 7960). This intercom feature gets configured by using the DN configuration and end user (manager and assistant) configuration windows.
- Cisco Unified Communications Manager intercom (used with Cisco Unified IP Phones 7941, 7961, 7970, and 7971). This intercom feature gets configured by using the intercom partition, intercom calling search space, intercom directory number, intercom translation pattern, DN, and end user (manager and assistant) configuration windows.

Restrictions

The following restrictions apply to Cisco Unified Communications Manager Assistant:

- Cisco Unified Communications Manager Assistant supports SIP on Cisco Unified IP Phones 7941/61 and 7970/71.
- Cisco Unified Communications Manager Assistant supports up to 3500 managers and 3500 assistants by configuring multiple Cisco IP Manager Assistant servers (pools). When multiple pools are enabled, a manager and all configured assistants for that manager should belong to the same pool.
- One manager can have up to 10 assigned assistants.
- One assistant can support up to 33 managers (if each manager has one Cisco Unified Communications Manager Assistant—Controlled Line).
- Cisco Unified Communications Manager Assistant supports up to 3500 managers and 3500 assistants per Cisco Unified Communications Manager cluster when you are using the MCS 7845 server.
- The Assistant Console does not support hunt groups/queues.
- The Assistant Console does not support record and monitoring.
- The Assistant Console does not support onhook transfer (the ability to transfer a call by pressing the Transfer softkey and going onhook to complete the transfer).
- The Assistant Console does not support the one-touch Call Pickup feature.
- Cisco Unified IP Phone 7940/41 supports only two lines or speed-dial buttons.
- When an upgrade to Cisco Unified Communications Manager Release 7.0(1) occurs, existing Cisco Unified Communications Manager Assistant users that use the incoming intercom line do not get upgraded automatically to the Cisco Unified Communications Manager Intercom feature.
- The system does not support calls between the Cisco Unified Communications Manager Intercom feature and regular lines (which may be configured as Cisco Unified Communications Manager Assistant Intercom lines).
- Cisco Unified IP Phones 7960 and 7940 support only the Cisco Unified Communications Manager Assistant Intercom lines feature. Cisco Unified IP Phones 7941, 7961, 7970, and 7971 support only the Cisco Unified Communications Manager intercom feature.
- To install the Assistant Console application on a computer with Microsoft Internet Explorer 6 (or later) on Windows XP, install the Microsoft Java Virtual Machine (JVM) with Windows XP Service Pack 1 before the Assistant Console installation.

Installing and Activating Cisco Unified Communications Manager Assistant

Cisco Tomcat loads the Cisco Unified Communications Manager Assistant, a servlet. Cisco Tomcat gets installed and started at Cisco Unified Communications Manager installation. For more information, see the [“Cisco Unified Communications Manager Assistant Architecture Overview”](#) section on page 9-2.

The administrator performs three steps after installation to make Cisco Unified Communications Manager Assistant available for system use:

1. Use Cisco Unified Serviceability Service Activation, located on the Tools menu, to activate the Cisco IP Manager Assistant service. Refer to the *Cisco Unified Serviceability Administration Guide*.
2. Configure the applicable service parameters for the Cisco IP Manager Assistant service. See the “[Setting the Service Parameters for Cisco Unified Communications Manager Assistant](#)” section on page 9-22.
3. Use the Serviceability Control Center Feature Service window to stop and start the Cisco IP Manager Assistant service. See the “[Starting the Cisco IP Manager Assistant Service](#)” section on page 9-27.

Note

If the managers and assistants will require Cisco Unified Communications Manager Assistant features to display (on the phone and assistant console) in any language other than English, verify that the locale installer is installed before configuring Cisco Unified Communications Manager Assistant. Refer to the *Cisco Unified Communications Operating System Administration Guide* for information on locale installers.

Configuring Cisco Unified Communications Manager Assistant with Proxy Line Support

For successful configuration of Cisco Unified Communications Manager Assistant, review the steps in the configuration checklist, perform the system, user, and device configuration requirements, and configure the managers and assistants.

Note

Cisco Unified Communications Manager Assistant with proxy line support coexists in the same Cisco Unified Communications Manager cluster with Cisco Unified Communications Manager Assistant with shared line support. For configuration information about shared line support, see [Configuring Cisco Unified Communications Manager Assistant with Shared Line Support](#).

The following sections provide configuration information:

- [Configuration Checklist for Cisco Unified Communications Manager Assistant with Proxy Line Support](#), page 9-13
- [System Configuration with Proxy Line Support](#), page 9-17
- [Setting the Service Parameters for Cisco Unified Communications Manager Assistant](#), page 9-22
- [Configuring Multiple Servers for Cisco Unified Communications Manager Assistant Scalability](#), page 9-25
- [Security Considerations](#), page 9-26
- [Starting the Cisco IP Manager Assistant Service](#), page 9-27
- [Cisco Unified IP Phone Service Configuration](#), page 9-27
- [Manager and Assistant Phone Configuration](#), page 9-27
- [Manager and Assistant Configuration](#), page 9-31

Configuration Checklist for Cisco Unified Communications Manager Assistant with Proxy Line Support

Table 9-1 shows the logical steps for configuring the Cisco Unified Communications Manager Assistant feature in Cisco Unified Communications Manager.

Before You Begin

The information in the checklist assumes that you have already configured the phones and the users and have associated the devices to the users. Refer to [Configuring an End User](#), [Associating Devices to an End User](#), and [Configuring Cisco Unified IP Phones](#) in the *Cisco Unified Communications Manager Administration Guide*.

Table 9-1 Cisco Unified Communications Manager Assistant Configuration Checklist with Proxy Line Support

Configuration Steps		Related Procedures and Topics
Step 1	Using Cisco Unified Serviceability, Service Activation, activate the Cisco IP Manager Assistant service.	Cisco Unified Serviceability Administration Guide
Step 2	<p>Configure system administration parameters:</p> <ul style="list-style-type: none"> • Add three partitions. • Add two calling search spaces. • Add the CTI route point for Cisco Unified Communications Manager Assistant. You can have only one route point per server. • Configure Cisco IP Manager Assistant service parameters. <p>Tip To automatically configure these system administration parameters, use the Cisco Unified Communications Manager Assistant Configuration Wizard. For more information, see the “Cisco Unified Communications Manager Assistant Configuration Wizard” section on page 9-17.</p> <ul style="list-style-type: none"> • Add the partition of the manager line to the calling search space of the Message Waiting Indicator (MWI) on and off number (if MWI is required). • If using the Cisco Unified Communications Manager intercom feature, add the Intercom partition, Intercom calling search space, Intercom directory number, and the Intercom translation pattern. 	<p>Calling Search Space and Partitions, page 9-20</p> <p>Configuring a Partition, <i>Cisco Unified Communications Manager Administration Guide</i></p> <p>Configuring a Calling Search Space, <i>Cisco Unified Communications Manager Administration Guide</i></p> <p>Cisco Unified Communications Manager Assistant CTI Route Point, page 9-21</p> <p>Configuring a CTI Route Point, <i>Cisco Unified Communications Manager Administration Guide</i></p> <p>Cisco Unified Communications Manager Assistant Configuration Wizard, page 9-17</p> <p>Setting the Service Parameters for Cisco Unified Communications Manager Assistant, page 9-22</p> <p>Service Parameters Configuration, <i>Cisco Unified Communications Manager Administration Guide</i></p> <p>Message Waiting Configuration, <i>Cisco Unified Communications Manager Administration Guide</i></p> <p>Configuring Proxy, Incoming Intercom, and Primary Lines for the Assistant, page 9-35</p> <p>Intercom, page 22-1</p>

Table 9-1 Cisco Unified Communications Manager Assistant Configuration Checklist with Proxy Line Support (continued)

Configuration Steps		Related Procedures and Topics
Step 3	<p>If multiple Cisco Unified Communications Manager Assistant pools are required to support large numbers of assistants and managers, configure the following Cisco IP Manager Assistant clusterwide service parameters:</p> <ul style="list-style-type: none"> • Enable Multiple Active Mode • Pool 2 and Pool 3 Cisco IPMA Server IP Address 	Configuring Multiple Servers for Cisco Unified Communications Manager Assistant Scalability, page 9-25
Step 4	<p>Configure the application user CAPF profile (optional).</p> <p>Configure Cisco IP Manager Assistant service parameters for security (optional).</p>	Setting the Service Parameters for Cisco Unified Communications Manager Assistant, page 9-22 Security Considerations, page 9-26
Step 5	<p>Using the Serviceability Control Center Feature Services, stop and start the Cisco IP Manager Assistant service.</p>	Starting the Cisco IP Manager Assistant Service, page 9-27
Step 6	<p>Configure phone parameters:</p> <ul style="list-style-type: none"> • Add Assistant Primary Service as a Cisco Unified IP Phone service. If necessary, add Assistant Secondary service pointing to the Cisco Unified Communications Manager Assistant backup server as a Cisco Unified IP Phone service. • Configure Cisco Unified IP Phone. 	Cisco Unified IP Phone Service Configuration, page 9-27 Configuring an IP Phone Service, Cisco Unified Communications Manager Administration Guide Configuring Phone Button Templates, Cisco Unified Communications Manager Administration Guide
Step 7	<p>Configure manager and assistant Cisco Unified IP Phone parameters:</p> <ul style="list-style-type: none"> • Set up manager phone. • Set up assistant phone. 	Configuring Cisco Unified IP Phones, Cisco Unified Communications Manager Administration Guide

Table 9-1 Cisco Unified Communications Manager Assistant Configuration Checklist with Proxy Line Support (continued)

Configuration Steps	Related Procedures and Topics
<p>Step 8 Configure manager phone settings:</p> <ul style="list-style-type: none"> • Assign a softkey template. • If using Do Not Disturb, configure the Do Not Disturb fields on the manager phone. • Add a primary line. • Set up voice-mail profile on primary line. • Add intercom line. • For Cisco Unified IP Phones 7940 and 7960, add speed dial for outgoing intercom targets • For Cisco Unified IP Phones 7941, 7961, 7970, and 7971, add the intercom capabilities. • Subscribe to Cisco Unified IP Phone Service, Cisco Unified Communications Manager Assistant Primary Phone Service. If necessary, subscribe to Cisco Unified IP Phone Service, Cisco Unified Communications Manager Assistant Secondary Phone Service. • Set user locale. • Reset the phone. <p>Tip To automatically configure some of the manager phone settings, choose the automatic configuration check box on the Manager Configuration window. For more information, see the “Manager Phones” section on page 9-28.</p>	<p>Manager and Assistant Phone Configuration, page 9-27</p> <p>Finding a Phone, Cisco Unified Communications Manager Administration Guide</p> <p>Configuring Cisco Unified IP Phones, Cisco Unified Communications Manager Administration Guide</p> <p>Directory Number Configuration Overview, Cisco Unified Communications Manager Administration Guide</p> <p>Do Not Disturb, page 18-1</p> <p>Intercom, page 9-10</p> <p>Intercom, page 22-1</p> <p>Configuring Speed-Dial Buttons, Cisco Unified Communications Manager Administration Guide</p> <p>Cisco Unified IP Phone Service Configuration, page 9-27</p> <p>Configuring IP Phone Services, Cisco Unified Communications Manager Administration Guide</p> <p>Resetting a Phone, Cisco Unified Communications Manager Administration Guide</p>

Table 9-1 Cisco Unified Communications Manager Assistant Configuration Checklist with Proxy Line Support (continued)

Configuration Steps	Related Procedures and Topics
<p>Step 9 Configure assistant phone settings:</p> <ul style="list-style-type: none"> • Assign a softkey template. • Add a Cisco Unified IP Phone Expansion Module (optional). • Add a primary line. • Add proxy lines for each configured manager. Add a voice-mail profile that is the same as the voice-mail profile on the manager primary line. • Add incoming intercom line. • For Cisco Unified IP Phones 7940 and 7960, add speed dial for outgoing intercom targets • For Cisco Unified IP Phones 7941, 7961, 7970, and 7971, add the intercom capabilities. • Set user locale. • Reset the phone. <p>Tip To automatically configure some assistant phone settings, choose the Automatic Configuration check box on the Assistant Configuration window. For more information, see the “Assistant Phones” section on page 9-29.</p>	<p>Manager and Assistant Phone Configuration, page 9-27</p> <p>Finding a Phone, Cisco Unified Communications Manager Administration Guide</p> <p>Deleting a Phone, Cisco Unified Communications Manager Administration Guide</p> <p>Directory Number Configuration Overview, Cisco Unified Communications Manager Administration Guide</p> <p>Intercom, page 9-10</p> <p>Intercom, page 22-1</p> <p>Configuring Speed-Dial Buttons, Cisco Unified Communications Manager Administration Guide</p> <p>Resetting a Phone, Cisco Unified Communications Manager Administration Guide</p>
<p>Step 10 Configure Cisco Unified Communications Manager Assistant application:</p> <ul style="list-style-type: none"> • Create a new manager. • Configure lines for manager. • Assign an assistant to a manager. • Configure lines for the assistant. • Configure intercom lines (optional). 	<p>Configuring a Manager and Assigning an Assistant for Proxy Line Mode, page 9-32</p> <p>Deleting Cisco Unified Communications Manager Assistant Information from the Manager, page 9-34</p> <p>Intercom, page 9-10</p> <p>Intercom, page 22-1</p> <p>Configuring Proxy, Incoming Intercom, and Primary Lines for the Assistant, page 9-35</p>
<p>Step 11 Configure the dial rules for the assistant.</p>	<p>Dial Rules Configuration, page 9-39</p>
<p>Step 12 Install the Assistant Console application.</p>	<p>Installing the Assistant Console Application, page 9-39</p>
<p>Step 13 Configure the manager and assistant console applications.</p>	<p>Cisco Unified Communications Manager Assistant User Guide</p>

System Configuration with Proxy Line Support

Because the Cisco IP Manager Assistant service intercepts calls that are made to managers who are using proxy line mode, it requires configuration of partitions, calling search spaces, and route points. For more information on configuring Cisco Unified Communications Manager Assistant, see the [“Configuration Checklist for Cisco Unified Communications Manager Assistant with Proxy Line Support”](#) section on page 9-13.

You must perform the following configurations before you configure devices and users for Cisco Unified Communications Manager Assistant:

- [Calling Search Space and Partitions, page 9-20](#)
- [Cisco Unified Communications Manager Assistant CTI Route Point, page 9-21](#)

Cisco Unified Communications Manager Assistant provides a one-time-use configuration wizard that helps the administrator configure partitions, calling search spaces, a route point, and the Cisco Unified Communications Manager Assistant phone service. The Cisco Unified Communications Manager Assistant Configuration Wizard also creates the Cisco IP Manager Assistant service parameters in the IPMA Device Configuration Defaults section. For more information on the Cisco Unified Communications Manager Assistant Configuration Wizard, see the [“Cisco Unified Communications Manager Assistant Configuration Wizard”](#) section on page 9-17.



Note

This document provides specific information about Cisco Unified Communications Manager Assistant configuration. For more information about configuring Calling Search Spaces, Partitions, and CTI Route Points, refer to the *Cisco Unified Communications Manager Administration Guide*.

Cisco Unified Communications Manager Assistant Configuration Wizard

With the Cisco Unified Communications Manager Assistant Configuration Wizard, configuration takes less time and eliminates errors. The partitions, calling search spaces, and route point automatically get created when the administrator successfully runs and completes the configuration wizard. The wizard also creates BAT templates for the manager phone, the assistant phone, and all other user phones. The administrator can use the BAT templates to configure the managers, assistants, and all other users. Refer to the *Cisco Unified Communications Manager Bulk Administration Guide*.



Note

The Cisco Unified Communications Manager Assistant Configuration Wizard only creates the Cisco IP Manager Assistant service parameters in the IPMA Device Configuration Defaults section of the Service Parameters Configuration window. You must enter the remaining service parameters manually. For service parameter information, see the [“Setting the Service Parameters for Cisco Unified Communications Manager Assistant”](#) section on page 9-22.

The Cisco Unified Communications Manager Assistant Configuration Wizard provides windows for each configuration parameter. The windows provide the administrator with preconfigured information. If the administrator prefers to use other configuration information (for example, partition names), the administrator can change the preconfigured information to the appropriate information.

Perform the following procedure to configure the Cisco Unified Communications Manager Assistant system parameters by using the Cisco Unified Communications Manager Assistant Configuration Wizard.

Before You Begin

Ensure that the configuration wizard runs from the same server (the Cisco Unified Communications Manager server) as the Bulk Administration Tool (BAT).

Procedure

- Step 1** From Cisco Unified Communications Manager Administration, choose **Application > Cisco Unified CM Configuration Wizard**.

The Cisco Unified Communications Manager Assistant Configuration Wizard Overview window displays and provides a description of the configuration wizard process.



Note You can use the Cisco Unified Communications Manager Assistant Configuration Wizard only once in a Cisco Unified Communications Manager cluster configuration. The feature verifies the number of times that the configuration wizard has been run (zero or 1). If the configuration wizard has been run once, the summary window automatically displays. The summary window displays the details and status of the configuration wizard that was previously run. If the configuration has not been run, the configuration process continues.

- Step 2** To begin the Cisco Unified Communications Manager Assistant Configuration wizard process, click the **Next** button.
The Partition for Managers window displays.
- Step 3** Enter a name in the partition name field and provide a description; otherwise, use the default partition name and description.
- Step 4** Click the **Next** button.
The CTI Route Point Partition window displays.
- Step 5** Enter a name in the CTI route point name field and provide a description; otherwise, use the default CTI route point name.
- Step 6** Click the **Next** button.
The Partition for All Users window displays.
- Step 7** Enter a name in the partition name field and provide a description; otherwise, use the default partition name and description.
- Step 8** Click the **Next** button.
The Intercom Partition window displays.
- Step 9** Enter a name in the name field and provide a description; otherwise, use the default Intercom Partition name.
- Step 10** Click the **Next** button.
The Assistant Calling Search Space window displays.
- Step 11** Enter a name in the name field and provide a description; otherwise, use the default calling search space name and description.
The Available Partitions and Selected Partitions boxes under the Route Partitions for this Calling Search Space automatically list Partitions for the Assistant Calling Search Space. If the defaults that are provided are not wanted, the administrator can choose the applicable partition from the Available Partitions box. Use the up and down arrows to move partitions from one box to the other.

Step 12 Click the **Next** button.

The Everyone Calling Search Space window displays.

Step 13 Enter a name in the name field and provide a description; otherwise, use the default calling search space name and description.

The Available Partitions and Selected Partitions boxes under the Additional Route Partitions for This Calling Search Space automatically list Partitions for the Everyone Calling Search Space. If the defaults that are provided are not wanted, the administrator can choose the applicable partition from the Available Partitions box. Use the up and down arrows to move partitions from one box to the other.

Step 14 Click the **Next** button.

If you have existing calling search spaces that are configured in the system, the Existing Calling Search Spaces window displays; otherwise, the Existing Calling Search Spaces window does not display (proceed to Step 15).

Cisco Unified Communications Manager Assistant requires that existing calling search spaces add the prefix Generated_Route Point and Generated_Everyone partitions. The Available and Selected Partitions boxes automatically list these partitions. Use the up and down arrows to move partitions from one box to the other.



Note The prefix that is added to the existing calling search spaces may change if the administrator has changed the names of the partitions in Steps 10 and 12.

Step 15 Click the **Next** button.

The CTI Route Point window displays.

Step 16 Enter a name in the CTI route point name field; otherwise, use the default CTI route point name.

Step 17 From the drop-down selection list box, choose the appropriate device pool.

Step 18 Enter a route point directory number; otherwise, use the default route point directory number.

Step 19 From the drop-down selection list box, choose the appropriate numbering plan.

Step 20 Click the **Next** button.

The Phone Services window displays.

Step 21 Enter the Primary Phone Service Name; otherwise, use the default Phone Service name.

Step 22 From the drop-down list box, choose the Primary Cisco Unified Communications Manager Assistant server or enter a server name or IP address.

Step 23 Enter the Secondary Phone Service Name; otherwise, use the default Phone Service name.

Step 24 From the drop-down list box, choose the secondary Cisco Unified Communications Manager Assistant server or enter a server name or IP address.

Step 25 Click the **Next** button.

The Confirmation window displays. It provides all the information that the administrator chose while using the configuration wizard. If the information is not correct, the administrator can cancel the configuration process or return to the previous configuration windows by pressing the **Back** button.

Step 26 To allow the configuration process to execute, click the **Finish** button; otherwise, to cancel the configuration process, click the **Cancel** button.

Upon completion, a final status window displays. The window shows the success or failure of each part of the wizard.

Any errors that the configuration wizard generates get sent to a trace file. Access this file by using the following CLI command:

```
file get activelog tomcat/logs/ccmadmin/log4j
```

With the data that is collected from the configuration windows, the wizard automatically creates the partitions, calling search spaces, a route point, and the Cisco Unified Communications Manager Assistant phone services. The wizard populates the Cisco IP Manager Assistant service parameters in the IPMA Device Configuration Defaults section of the Service Parameters Configuration window. Additionally, the wizard creates the manager phone template, the assistant phone template, and the Everyone phone template that BAT uses to configure phones for use with Cisco Unified Communications Manager Assistant. Refer to the *Cisco Unified Communications Manager Bulk Administration Guide* for information about configuring the manager and assistant devices.

Calling Search Space and Partitions

A Cisco Unified Communications Manager Assistant route point (called CTI route point) intercepts calls for the managers and determines where to route them; therefore, all calls for the managers should flow through the route point first.

To accomplish the call flow, Cisco Unified Communications Manager Assistant uses calling search spaces. Calls from lines that the Cisco IP Manager Assistant service must route or act upon should have a calling search space that has the route point partition (you can call this partition CTI Route Point) that is configured as the primary partition, and you can call the secondary partition the Everyone partition. See the following example.



Note

For a manager who has multiple lines and who uses proxy line support, those lines must fall in the range that is covered by the route point (for example, a route point of 1xxx means that manager lines must fall in 1000 - 1999 range).

Example

A user (in Everyone partition) places a call to a manager primary line (in Manager partition). Because the partition for the originating call does not include the manager primary line, the manager line number gets searched through the calling search space. The order of priority of the partitions in the calling search space provides basis for the search. Because the user line has a calling search space that comprises CTI Route Point and Everyone, the search for the manager primary line begins with the CTI route point partition. Because the CTI route point matches the manager primary number, the call gets presented to the route point. The Cisco IP Manager Assistant service that is monitoring the route point gets the call and routes the call by using the manager settings.

All lines that have calls that should go through a route point should have a calling search space that is called Cisco Unified Communications Manager Assistant and Everyone. Examples of lines that require this calling search space configuration include manager primary and private lines, assistant primary line, and all other user lines.

All lines that have calls that should go directly to the manager without having the routing logic applied on them should have a calling search space that is called Managers and Everyone. Examples of lines that require this calling search space configuration include Cisco CTI route point and assistant proxy lines.

See [Figure 9-4](#) for an example of the calling search space and partition configuration.

Figure 9-4 Cisco Unified Communications Manager Assistant Calling Search Space and Partition Configuration Example for Proxy Line Support

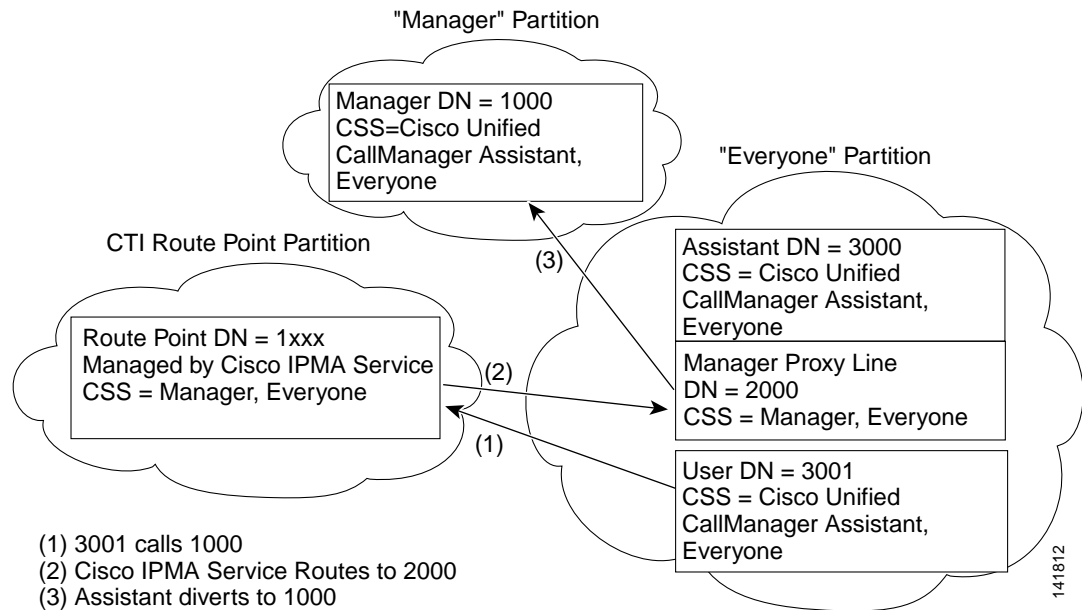

Configuration Tips

- Create three partitions that are called CTI Route Point, Manager, and Everyone.
- Create a calling search space that is called CSS-M-E, which contains the partitions Manager and Everyone.
- Create a calling search space that is called CSS-I-E, which contains the partitions CTI Route Point and Everyone.
- Configure the manager primary and private directory numbers (DN) in the partition that is called Manager.
- Configure all assistants lines and other users lines in the partition that is called Everyone.
- Configure the Cisco Unified Communications Manager Assistant route point in the partition that is called CTI Route Point.
- Configure the MWI On/Off numbers with a calling search space CSS-M-E.

Cisco Unified Communications Manager Assistant CTI Route Point

You can have only one Cisco Unified Communications Manager Assistant CTI route point for each server. The directory numbers of CTI route points must match the primary and private directory numbers of the manager; otherwise, the Cisco IP Manager Assistant service routes calls inappropriately. Cisco recommends the use of wild cards to satisfy this condition.

When you add directory number ranges for the CTI route point, the caller search space must not contain the Manager partition because Cisco Unified Communications Manager always matches on the most specific match regardless of partition order; for example, the manager line is 1000, and the directory number range that is added to the route point is 1xxx. If a caller search space includes the Manager partition, even when the CTI Route Point partition is at the top, the more specific match applies for the manager directory number, and the call does not get routed by Cisco Unified Communications Manager.

Assistant but gets sent directly to the manager extension. For Cisco Unified Communications Manager Assistant to route the call when using directory number ranges on the route point, the caller search space must include the CTI Route Point partition but not the Manager partition.

Configuration Tips

- Create a CTI route point that is called Assistant_RP.
- Configure the directory numbers of the route point to match the primary and private directory numbers of the managers (for example, for managers whose primary directory numbers are 1000-1999, create a route point DN as 1xxx for line 1; for managers whose primary directory numbers are 2000-2999, create a route point DN as 2xxx for line 2). Configure the directory numbers in the CTI Route Point partition with a calling search space of CSS-M-E.
- Configure Call Forward No Answer with Destination Internal/External as Route Point DN (for example, CFNA as 1xxx for the Route Point DN 1xxx) with a calling search space of CSS-M-E. Call Forward No Answer forwards the call to the manager if the Cisco IP Manager Assistant service is not available.

Setting the Service Parameters for Cisco Unified Communications Manager Assistant

Service parameters for the Cisco IP Manager Assistant service comprise two categories: general and clusterwide. Specify clusterwide parameters once for all Cisco IP Manager Assistant services. Specify general parameters for each Cisco IP Manager Assistant service that is installed.

Set the Cisco IP Manager Assistant service parameters by using Cisco Unified Communications Manager Administration to access the service parameters (**System > Service Parameters**). Choose the server where the Cisco Unified Communications Manager Assistant application resides and then choose the Cisco IP Manager Assistant service.

Cisco IP Manager Assistant includes the following service parameters that must be configured:

- Clusterwide
 - Cisco IPMA Server (Primary) IP Address—No default. Administrator must manually enter this IP address. Administrator can assign up to 2500 managers and assistants to this address.
 - Cisco IPMA Server (Backup) IP Address—No default. Administrator must manually enter this IP address.
 - Cisco IPMA Server Port—Default specifies Port 2912.
 - Cisco IPMA Assistant Console Heartbeat Interval—Default specifies 30 seconds. This interval timer specifies how long it takes for the failover to occur on the assistant console.
 - Cisco IPMA Assistant Console Request Timeout—Default specifies 30 seconds.
 - Cisco IPMA RNA Forward Calls—Default specifies False. If the parameter is set to True, an assistant phone that does not get answered will forward to another assistant phone.
 - Cisco IPMA RNA Timeout—Default specifies 10 seconds. RNA timeout specifies how long an assistant phone can go unanswered before the call is forwarded to another assistant phone. If Call Forward No Answer (CFNA) and RNA timeout are both configured, the first timeout occurrence takes precedence.
 - CTIManager Connection Security Flag has the following two options:
 - Nonsecure—The security mode specifies nonsecure.

Use Cluster Default—Cisco IP Manager Assistant service fetches the security mode for the cluster. If the cluster security mode is detected as mixed, Cisco Unified Communications Manager Assistant will open a secure connection to CTI Manager by using the Application CAPF profile. To make the secure connection succeed, configure both the “CTI Manager Connection Security Flag” and the “CAPF Profile Instance ID for Secure Connection to CTI Manager” parameters.

- Advanced Clusterwide
 - Enable Multiple Active Mode—The default specifies False. When set to True, the administrator can configure up to 7000 managers and assistants by using multiple pools.
 - Pool 2: Cisco IPMA Server (Primary) IP Address—No default. Administrator must manually enter this IP address. Administrator can assign up to 2500 managers and assistants to this address.
 - Pool 2: Cisco IPMA Server (Backup) IP Address—No default. Administrator must manually enter this IP address.
 - Pool 3: Cisco IPMA Server (Primary) IP Address—No default. Administrator must manually enter this IP address. Administrator can assign up to 2500 managers and assistants to this address.
 - Pool 3: Cisco IPMA Server (Backup) IP Address—No default. Administrator must manually enter this IP address.
- Cisco IPMA Service Parameters for each server
 - CTIManager (Primary) IP Address—No default. Enter the IP address of the primary CTIManager that will be used for call control.
 - CTIManager (Backup) IP Address—No default. Administrator must manually enter this IP address.
 - Route Point Device Name for Proxy Mode—No default. Choose the Cisco Unified Communications Manager Assistant route point device name (that you configure by using **Device > CTI Route Point**).
 - CAPF Profile Instance Id for Secure Connection to CTIManager—This service parameter specifies the Instance Id of the Application CAPF Profile for the Application User IPMASecureSysUser that this Cisco Unified Communications Manager Assistant server will use to open a secure connection to CTIManager. You must configure this parameter if CTIManager Connection Security Flag is enabled.

Cisco Unified Communications Manager Assistant includes the following clusterwide parameters that must be configured if you want to use the Cisco Unified Communications Manager Assistant automatic configuration for managers and assistants:

- Softkey Templates
 - Assistant Softkey Template—Default specifies Standard Assistant softkey template. This parameter specifies the softkey template that is assigned to the assistant device during assistant automatic configuration.
 - Manager Softkey Template for Proxy Mode—Default specifies Standard Manager softkey template. This parameter specifies the softkey template that is assigned to the manager device during manager automatic configuration.
 - Manager Softkey Template for Shared Mode—Default specifies Standard Shared Mode Manager. This service parameter does not apply to proxy line support.

- IPMA Device Configuration Defaults
 - Manager Partition—No default. This parameter specifies the partition that the automatic configuration assigns to the manager line(s) that Cisco Unified Communications Manager Assistant handles on the manager device. Enter a partition that exists in the system. If you run the Cisco Unified Communications Manager Assistant Configuration Wizard, the wizard populates this value.
 - All User Partition—No default. This parameter specifies the partition that the automatic configuration assigns to the proxy line(s) and the intercom line on the assistant device as well as the intercom line on the manager device. Enter a partition that exists in the system. If you run the Cisco Unified Communications Manager Assistant Configuration Wizard, the wizard populates this value.
 - IPMA Calling Search Space—No default. This parameter specifies the calling search space that the automatic configuration assigns to the manager line(s) that Cisco Unified Communications Manager Assistant handles and the intercom line on the manager device as well as the assistant intercom line on the assistant device. Enter a calling search space that exists in the system. If you run the Cisco Unified Communications Manager Assistant Configuration Wizard, the wizard populates this value.
 - Manager Calling Search Space—No default. This parameter specifies the calling search space that the automatic configuration assigns to the proxy line(s) on the assistant device. Enter a calling search space that exists in the system. If you run the Cisco Unified Communications Manager Assistant Configuration Wizard, the wizard populates this value.
 - Cisco IPMA Phone Service—No default. This parameter specifies the IPMA phone service that the automatic configuration assigns to the manager device. If you run the Cisco Unified Communications Manager Assistant Configuration Wizard, the wizard populates this value.
 - IPMA Secondary Phone Service—No default. This parameter specifies a secondary IPMA phone service that the automatic configuration assigns to the manager device if the primary service is not available.
- Proxy Directory Number Range
 - Starting Directory Number—No default. The Starting Directory Number and the Ending Directory Number parameters provide a range of proxy numbers that are available for the assistant configuration. The Starting Directory Number parameter specifies the first directory number in the range. The next available number in the range displays in the Proxy Line field in the End User Configuration window when you are configuring an assistant.
 - Ending Directory Number—No default. The Starting Directory Number and the Ending Directory Number parameters provide a range of proxy numbers that are available for the assistant configuration. The Ending Directory Number parameter specifies the last directory number in the range. If you enter a smaller value in the Ending Directory Number field than you do in the Starting Directory Number field, a message displays when you access the Assistant Configuration in the End User Configuration window.
- Proxy Directory Number Prefix
 - Number of Characters to be Stripped from Manager Directory Number—Default specifies 0. This parameter specifies the number of characters that Cisco Unified Communications Manager strips from a manager directory number (DN) in the process of generating a proxy DN. You can use this parameter along with the Prefix for Manager Directory Number parameter to generate a proxy DN. For example, if you strip 2 digits from a manager DN of 2002 and add a prefix of 30 (specified in the Prefix for Manager Directory Number service parameter), Cisco Unified Communications Manager generates a proxy DN of 3002. You can strip 0 to 24 characters.

- Prefix for Manager DN—No default. This parameter specifies the prefix that Cisco Unified Communications Manager adds to a manager DN in the process of generating the proxy DN. For example, if manager DN is 1001, number of characters to be stripped is 0, and the prefix is *, Cisco Unified Communications Manager generates a proxy DN of *1001. The maximum prefix length equals 24.

Configuring Multiple Servers for Cisco Unified Communications Manager Assistant Scalability

Cisco Unified Communications Manager supports up to 3500 managers and 3500 assistants for a total of 7000 users. To support 7000 users, the administrator must configure multiple active Cisco IP Manager Assistant servers by enabling and setting service parameters. Administrators can configure up to three active Cisco IP Manager Assistant servers, each managing up to 2500 managers and assistants. Each server can also have a backup server. Configure the Cisco IP Manager Assistant servers by using the Advanced Service Parameters, Enable Multiple Active Mode, Pool 2: Cisco IPMA Server, and Pool3: Cisco IPMA Server. See the [“Setting the Service Parameters for Cisco Unified Communications Manager Assistant”](#) section on page 9-22 for more information. See [Figure 9-5](#).

Figure 9-5 Scalability Architecture

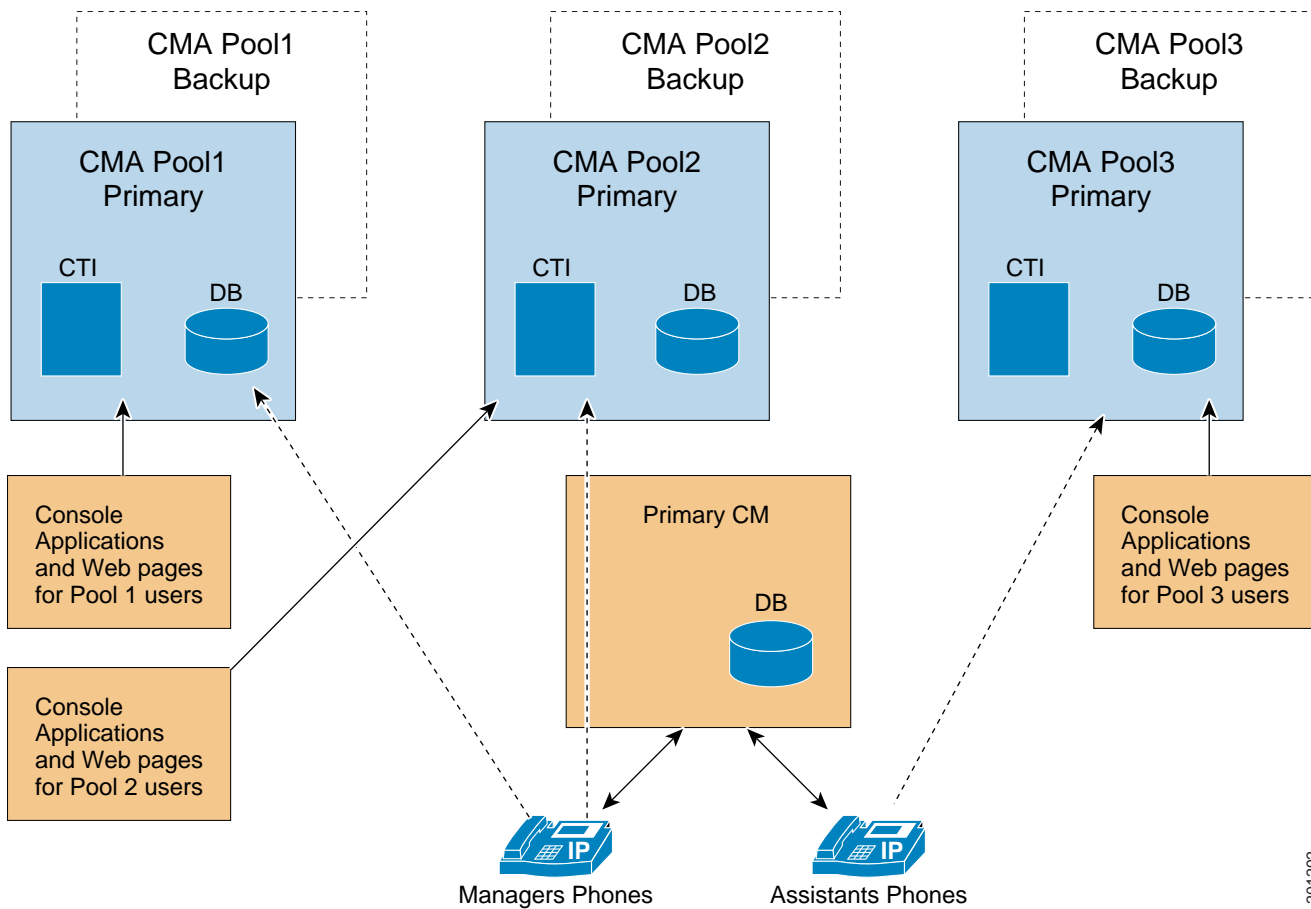

1. Activate IPMA service (see the “Installing and Activating Cisco Unified Communications Manager Assistant” section on page 9-11)
2. Enable multiple active mode (see the “Setting the Service Parameters for Cisco Unified Communications Manager Assistant” section on page 9-22)
3. Provide IP addresses for multiple pools (see the “Setting the Service Parameters for Cisco Unified Communications Manager Assistant” section on page 9-22)
4. Add the pool to the manager/assistant from the End User Configuration window (see the “Configuring a Manager and Assigning an Assistant for Proxy Line Mode” section on page 9-32)

Migration Considerations

If you are migrating from a release previous to Cisco Unified Communications Manager Release 7.0(1), all managers and assistants will get migrated to Pool 1 (the default).

Security Considerations

Cisco Unified Communications Manager Assistant supports a secure connection to CTI (transport layer security connection).

The administrator must configure a CAPF profile (one for each Cisco Unified Communications Manager Assistant node) by choosing **User Management > Application User CAPF Profile**. From the Application User drop-down list box that is on the Application User CAPF Profile Configuration window, the administrator chooses IPMASecureSysUser.

For more information about configuring security for Cisco Unified Communications Manager Assistant, see the information on the CTIManager Connection Security Flag and the CAPF Profile Instance Id for Secure Connection to CTIManager service parameters in the [“Setting the Service Parameters for Cisco Unified Communications Manager Assistant”](#) section on page 9-22.

The *Cisco Unified Communications Manager Security Guide* provides detailed security configuration procedures for CTI applications.

Starting the Cisco IP Manager Assistant Service

The Cisco IP Manager Assistant service runs as an application on Cisco Tomcat. To start or stop the Cisco IP Manager Assistant service, use the Serviceability Control Center Feature Services window.

Cisco Unified IP Phone Service Configuration

Add the Cisco IP Manager Assistant service as a new Cisco Unified IP Phone Service. Configure a name, description, and the URL for the Cisco IP Manager Assistant service. The name and description that you enter should be in the local language because it displays on the manager Cisco Unified IP Phone. For more information, see [IP Phone Services Configuration](#) in the *Cisco Unified Communications Manager Administration Guide*.

Provide a URL by using the format

```
http://<server-ipaddress>:8080/ma/servlet/MAService?cmd=doPhoneService&Name=#DEVICENAME#
```

For example

```
http://123.45.67.89:8080/ma/servlet/MAService?cmd=doPhoneService&Name=#DEVICENAME#
```

Configuration Tips

To provide redundancy for the Cisco Unified IP Phone Service, create a Cisco Unified IP Phone Service that uses the host name rather than the IP address. The host name in DNS should resolve to both Cisco Unified Communications Manager Assistant primary and backup IP addresses. The phone functionality for softkeys and filtering, as well as the phone service, will fail over automatically in the case of a failover.

Manager and Assistant Phone Configuration

You must configure devices for each manager and assistant. Before you begin, complete the following tasks, depending on the phone type.

Cisco Unified IP Phone 7940/41, 7960/61, and 7970/71 (SCCP and SIP)

- Add a Cisco Unified IP Phone 7940/41, 7960/61, or 7970/71 for each manager and assistant that will be using Cisco Unified Communications Manager Assistant. To add these phones, use one of the following methods:
 - Manually (**Device > Phone**)

- Auto registration
- BAT
- Assign the Standard Assistant or Standard Manager softkey template.

Cisco Unified IP Phone 7940/41

You can use the Cisco Unified IP Phone 7940/41 for Cisco Unified Communications Manager Assistant, but certain restrictions apply.

- Add a Cisco Unified IP Phone 7940/41 for each manager with the following items configured:
 - Two lines, one for the primary line and one for the intercom
 - Softkey template for manager with shared line support
- Add a Cisco Unified IP Phone 7940/41 for each assistant with the following items configured:
 - Two lines, one for the primary line and one for the intercom
 - Softkey template for assistant



Note

Cisco supports the Cisco Unified IP Phone 7940/41 for Cisco Unified Communications Manager Assistant but recommends the Cisco Unified IP Phone 7960/61 or 7970/71 because they provide more functionality.



Note

Cisco Unified IP Phone 7940/60 supports only the Cisco Unified Communications Manager Assistant intercom feature.

After you complete these tasks, configure the phones as described in the following sections:

- [Manager Phones, page 9-28](#)
- [Assistant Phones, page 9-29](#)
- [Nonmanager and Nonassistant Phones, page 9-31](#)

Manager Phones

The following section describes the Cisco Unified Communications Manager Assistant requirements and tips for configuring a manager phone.

Manager Phone Configuration

Configure the manager Cisco Unified IP Phones with the following settings:

- Standard Manager softkey template
- Primary line
- Additional lines if required
- Voice-messaging profile on primary line
- If using the Cisco Unified IP Phone 7941, 7961, 7970, or 7971, configure the intercom feature
- If using the Cisco Unified IP Phone 7940/60, configure the incoming intercom line to support the auto answer with speakerphone or headset option
- If using the Cisco Unified IP Phone 7940/60, configure the speed dial for outgoing intercom targets

- Subscribe to Cisco Unified IP Phone Service, Assistant Primary Phone Service. If necessary, subscribe to Cisco Unified IP Phone Service, Assistant Secondary Phone Service.
- Set user locale

You can automate some of these settings by choosing the Automatic Configuration check box on the Manager Configuration window when you configure the manager. Automatic Configuration sets the following items for the manager device or device profile:

- Softkey template
- Subscription to Cisco Unified Communications Manager Assistant phone service
- Calling search space and partition for Cisco Unified Communications Manager Assistant-controlled selected lines and intercom line (applies only to Cisco Unified IP Phone 7940/60)
- Auto answer with speakerphone for intercom line (applies only to Cisco Unified IP Phone 7940/60)

Before you can automatically configure a manager phone, you must set the Cisco IP Manager Assistant service parameters in the IPMA Device Configuration Defaults section. These parameters specify information such as which partition and calling search space to use for a manager line. You can enter these parameters manually, or you can populate the parameters by using the Cisco Unified Communications Manager Assistant Configuration Wizard. For more information about these parameters, see the [“Setting the Service Parameters for Cisco Unified Communications Manager Assistant” section on page 9-22](#). For more information on the Cisco Unified Communications Manager Assistant Configuration Wizard, see the [“Cisco Unified Communications Manager Assistant Configuration Wizard” section on page 9-17](#).

After you enter the appropriate service parameters, you can automatically configure a manager phone by choosing the **Automatic Configuration** check box on the Manager Configuration window and clicking **Save**. For step-by-step instructions, see the [“Configuring a Manager and Assigning an Assistant for Proxy Line Mode” section on page 9-32](#).

Configuration Tips for Manager

- Do not configure Call Forward All Calls on the manager primary DN because the manager cannot intercept calls that are routed to the assistant proxy DN when Call Forward All Calls is set.
- Configure primary lines (Cisco Unified Communications Manager Assistant-controlled lines) and assign DNs; use the Managers partition and the CSS-I-E calling search space for these lines if you are not using the automatic configuration.
- If the manager is using the Cisco Unified IP Phone 7940 or 7960, configure an incoming intercom line and assign a DN; use the Everyone partition and the CSS-I-E calling search space if you are not using the automatic configuration.
- If the manager is using the Cisco Unified IP Phone 7941, 7961, 7970, or 7971 and requires intercom, add the intercom DN and choose the applicable intercom partition and intercom calling search space.

Cisco Unified Communications Manager Assistant supports the Cisco Unified IP Phone 7940/41. For more information, see the [“Cisco Unified IP Phone 7940/41” section on page 9-28](#).

Assistant Phones

The following section describes the Cisco Unified Communications Manager Assistant requirements and provides tips for configuring an assistant phone.

Assistant Phone Configuration

Configure the assistant Cisco Unified IP Phones with the following settings:

- Standard Assistant softkey template
- Default expansion module (optional)
- Standard Assistant phone button template (if using an expansion module)
- Primary line
- Proxy lines for each configured manager with a voice-mail profile that is the same as the manager voice-mail profile
- Incoming intercom line to support the auto answer with speakerphone or headset option (applies only to Cisco Unified IP Phone 7940/60)
- Speed dial to incoming intercom line for each configured manager (applies only to Cisco Unified IP Phone 7940/60)
- Set user locale
- Subscribe to Cisco Unified IP Phone Service, Assistant Primary Phone Service. If necessary, subscribe to Cisco Unified IP Phone Service, Assistant Secondary Phone Service.

You can automate some settings by choosing the Automatic Configuration check box on the Assistant Configuration window when you configure the assistant. Automatic Configuration sets the following items for the assistant device or device profile:

- Softkey template
- Phone button template
- Calling search space and partition for existing proxy lines and intercom line
- Auto answer with speakerphone for intercom line
- Autogenerated proxy lines creation, if chosen

Before you can automatically configure an assistant phone, you must set the Cisco IP Manager Assistant service parameters in the IPMA Device Configuration Defaults section. These parameters specify information such as which partition and calling search space to use for assistant proxy and intercom lines. You can enter these parameters manually, or you can populate the parameters by using the Cisco Unified Communications Manager Assistant Configuration Wizard. For more information about these parameters, see the [“Setting the Service Parameters for Cisco Unified Communications Manager Assistant” section on page 9-22](#). For more information on the Cisco Unified Communications Manager Assistant Configuration Wizard, see the [“Cisco Unified Communications Manager Assistant Configuration Wizard” section on page 9-17](#).

After you have entered the appropriate service parameters, you can automatically configure an assistant phone by choosing the **Automatic Configuration** check box on the Assistant Configuration window. For step-by-step instructions, see the [“Configuring Proxy, Incoming Intercom, and Primary Lines for the Assistant” section on page 9-35](#).

Automatic configuration allows you to create a proxy line automatically (with the required calling search space and partition information) on the assistant phone. The autogenerated proxy numbers get generated from the values that you enter for the Proxy Directory Number Range and Proxy Directory Number Prefix service parameters as described in the [“Setting the Service Parameters for Cisco Unified Communications Manager Assistant” section on page 9-22](#).

Autogenerated numbers appear along with lines on the assistant device in the Proxy Line drop-down list box on the Assistant Configuration window when you configure the assistant. “Line” appears before existing lines on the assistant phone. “Auto” appears before each autogenerated number until the system adds that proxy line to an assistant phone. The system sets the calling search space and partition for the

proxy line and the intercom line, if any, on the basis of the Cisco IP Manager Assistant service parameter settings. For step-by-step instructions, see the [“Configuring Proxy, Incoming Intercom, and Primary Lines for the Assistant”](#) section on page 9-35.

Configuration Tips for Assistant

- If the assistant is using the Cisco Unified IP Phone 7940 or 7960, configure an incoming intercom line and assign a DN; use the Everyone partition and the CSS-I-E calling search space if you are not using the automatic configuration.
- If the assistant is using the Cisco Unified IP Phone 7941, 7961, 7970, or 7971 and requires intercom, add the intercom DN and choose the applicable intercom partition and intercom calling search space.
- Configure a proxy line and assign a DN for each manager that the assistant will support; use the Everyone partition and the CSS-M-E calling search space if you are not using the automatic configuration.

Cisco Unified Communications Manager Assistant supports the Cisco Unified IP Phone 7940/41. For more information, see the [“Cisco Unified IP Phone 7940/41”](#) section on page 9-28.

Nonmanager and Nonassistant Phones

In addition to configuring manager and assistant devices, configure all other users in the Cisco Unified Communications Manager cluster. Proper configuration allows managers and assistants to make calls to and receive calls from all other users in the cluster.

Configuration Tips for Nonmanager and Nonassistant

- Use the Everyone partition for all other users.
- Use the CSS-I-E calling search space for all other users.
- If you use auto registration, perform the following tasks:
 - On the Device Pool Configuration window (**System > Device Pool**), choose CSS-I-E from the Calling Search Space for Auto-registration field.
 - On the Cisco Unified Communications Manager Configuration window (**System > Cisco Unified Communications Manager**), choose Everyone from the Partition field.
- If you use BAT, you can use the Everyone template that the Cisco Unified Communications Manager Assistant Configuration Wizard created to add phones in the Everyone partition and the CSS-I-E calling search space.

Manager and Assistant Configuration

From the Cisco Unified Communications Manager End User Configuration window, configure the settings for the managers and assistants who use the Cisco Unified Communications Manager Assistant feature. You can configure Cisco Unified Communications Manager Assistant in proxy line or shared line mode. To configure the manager and assistant for proxy line mode, see the [“Configuring a Manager and Assigning an Assistant for Proxy Line Mode”](#) section on page 9-32. To configure the manager and assistant for shared line mode, see the [“Configuring a Manager and Assigning an Assistant for Shared Line Mode”](#) section on page 10-21.

From the End User Configuration window, perform the following functions:

- Choose manager and assistant devices.

- Automatically configure a manager or assistant device, if you want one.
- Choose the local language in which the User Information window displays.
- Choose the Manager Configuration or Assistant Configuration window to configure the following Cisco Unified Communications Manager Assistant settings:
 - Set up primary and incoming intercom lines for intercom capability. For example, configure extension 3102 as the intercom line for the manager. This line will receive intercom calls from the assistant; for example, the assistant line 1 (1102) and line 2 (1103) display on the assistant console, and the assistant answers them.



Note The intercom line that you choose will be the one that you created by using the Cisco Unified Communications Manager intercom feature (applicable only to Cisco Unified IP Phones 7941, 7961, 7979, and 7971) or by using speed dials (applicable only to Cisco Unified IP Phones 7940 and 7960).

- Configure assistant information for managers.
- Set up proxy lines for each manager on the assistant phone. For example, assistant lines 4 and 5 take calls from manager lines 1102 and 1103.

The following sections provide details about configuring the manager and assistant settings:

- [Configuring a Manager and Assigning an Assistant for Proxy Line Mode](#), page 9-32
- [Deleting Cisco Unified Communications Manager Assistant Information from the Manager](#), page 9-34
- [Configuring Proxy, Incoming Intercom, and Primary Lines for the Assistant](#), page 9-35
- [Deleting the Cisco Unified Communications Manager Assistant Information from the Assistant](#), page 9-37
- [Intercom](#), page 22-1

Configuring a Manager and Assigning an Assistant for Proxy Line Mode

Perform the following procedure to configure a manager and assign an assistant to the manager. To configure a new user, see “[Configuring an End User](#)” in the *Cisco Unified Communications Manager Administration Guide*.



Tip Configure manager information before configuring assistant information.

Procedure

-
- Step 1** To configure the manager and to assign an assistant to an existing user, choose **User Management > End User**.
 - Step 2** To find the user that will be the Cisco Unified Communications Manager Assistant manager, click the **Find** button or enter the user name in the Search Options field and click the **Find** button.
 - Step 3** To display user information for the chosen manager, click the user name.
The End User Configuration window displays.
 - Step 4** To configure Cisco Unified Communications Manager Assistant information for the manager, choose **Manager Configuration** from the Related Links drop-down list box and click **Go**.

- Step 5** The Manager Configuration window displays and contains manager information, assistant information, and controlled lines information for the chosen user.



Tip To view existing assistant configuration information, click the assistant name in the Associated Assistants list and click the **View Details** link. The Assistant Configuration information displays. To return to the manager configuration information, click the manager name in the Associated Managers list and click the **View Details** link.

- Step 6** To associate a device name or device profile with a manager, choose the device name or device profile from the Device Name/Profile drop-down list box. Extension mobility can optionally use device profiles. For information about using Cisco Extension Mobility with Cisco Unified Communications Manager Assistant, see the [“Extension Mobility” section on page 9-8](#).



Note If the manager telecommutes, click the Mobile Manager check box and optionally choose Device Profile. When Device Profile is chosen, the manager must log on to the phone by using extension mobility before accessing Cisco Unified Communications Manager Assistant.

- Step 7** From the Intercom Line drop-down list box, choose the intercom line appearance for the manager, if applicable.



Note The chosen intercom line applies to the Cisco Unified Communications Manager Assistant and Cisco Unified Communications Manager intercom features.

- Step 8** From the Assistant Pool drop-down list box, choose the appropriate Pool number (1 to 3).

- Step 9** To assign an assistant to the manager, choose an assistant from the Available Assistants list and click the down arrow to move the chosen assistant to the Associated Assistants list.

- Step 10** From the Available Lines selection box, choose a line that you want Cisco Unified Communications Manager Assistant to control and click the down arrow to make the line display in the Selected Lines selection box. Configure up to five Cisco Unified Communications Manager Assistant-controlled lines. To remove a line from the Selected Lines selection box and from Cisco Unified Communications Manager Assistant control, click the up arrow.

- Step 11** To automatically configure the softkey template, subscription to the Cisco Unified Communications Manager Assistant phone service, calling search space and partition for Cisco Unified Communications Manager Assistant—Controlled selected lines and intercom line, and auto answer with speakerphone for intercom line for the manager phone based on the Cisco IP Manager Assistant service parameters, check the **Automatic Configuration** check box.



Note Automatic Configuration for intercom applies only when using the Cisco Unified Communications Manager Assistant intercom feature for the Cisco Unified IP Phones 7940 and 7960.

- Step 12** Click the **Save** button.

The update takes effect immediately.

If you checked the Automatic Configuration check box and the service parameters are invalid, a message displays.

Upon successful completion of the automatic configuration, the manager device resets. If you configured a device profile, the manager must log out and log in to the device for settings to take effect.

**Note**

When non-Cisco Unified Communications Manager Assistant changes such as name, user locale, or PIN, are made to a user, the user (manager or assistant) must log out of Cisco Unified Communications Manager Assistant and log in before the changes occur.

Additional Information

See the [“Related Topics”](#) section on page 9-42.

Deleting Cisco Unified Communications Manager Assistant Information from the Manager

Perform the following procedure to delete Cisco Unified Communications Manager Assistant information for a manager. To delete non-Cisco Unified Communications Manager Assistant information for a manager, see the [“Configuring an End User”](#) section in the *Cisco Unified Communications Manager Administration Guide*.

Procedure

-
- Step 1** To search for the manager for whom you want to delete Cisco Unified Communications Manager Assistant information, choose **User Management > End User** from Cisco Unified Communications Manager Administration.
- Step 2** From the Find and List Users window, click the **Find** button or enter the user name in the Search Options field and click the **Find** button.
- A list of configured users displays.
- Step 3** Choose the manager whose information you want to delete.
- Step 4** From the Related Links drop-down list box, click **Manager Configuration**.
- The Manager Configuration window displays and contains manager configuration information.
- Step 5** Click the **Delete** button.
- The update takes effect immediately.
-

Additional Information

See the [“Related Topics”](#) section on page 9-42.

Updating the Manager Cisco Unified Communications Manager Assistant Configuration

Perform the following procedure to update Cisco Unified Communications Manager Assistant information for a manager. To update non-Cisco Unified Communications Manager Assistant information for a manager, see the [“Configuring an End User”](#) section in the *Cisco Unified Communications Manager Administration Guide*.

Procedure

-
- Step 1** To search for the manager for whom you want to update Cisco Unified Communications Manager Assistant information, choose **User Management > End User** from Cisco Unified Communications Manager Administration.
- Step 2** From the Find and List Users window, click the **Find** button or enter the user name in the Search Options field and click the **Find** button.
- A list of configured users displays.
- Step 3** Choose the manager whose information you want to update.
- Step 4** From the Related Links drop-down list box, click **Manager Configuration**.
- The Manager Configuration window displays and contains manager configuration information.
- Step 5** Update the information that you want changed such as device name, controlled lines, assistant, or intercom line appearance.



Note When the **Automatic Configuration** check box is checked, the system automatically configures the softkey template, subscription to the Cisco Unified Communications Manager Assistant phone service, calling search space and partition for Cisco Unified Communications Manager Assistant—Controlled selected lines and intercom line, and auto answer with speakerphone for intercom line for the manager phone based on the Cisco IP Manager Assistant service parameters.

- Step 6** Click the **Save** button.
- The update takes effect immediately.
-



Note When non-Cisco Unified Communications Manager Assistant changes such as name, user locale, or PIN are made to a user, the user (manager or assistant) must log out of Cisco Unified Communications Manager Assistant and log in for the changes to occur.

Additional Information

See the [“Related Topics” section on page 9-42](#).

Configuring Proxy, Incoming Intercom, and Primary Lines for the Assistant

Use the Assistant Configuration of the End User Configuration window to configure the following items:

- Device name of the assistant phone
- Intercom line that the assistant uses to answer the incoming intercom call (optional)
- Primary line to make outgoing calls (optional)
- Proxy line of the assistant phone that is associated with the manager, the manager name, and the manager line. For example, the assistant phone line 3 gets used to answer manager Mary Smith phone line 2.

A proxy line specifies a phone line that appears on the assistant Cisco Unified IP Phone. Cisco Unified Communications Manager Assistant uses proxy lines to manage calls that are intended for a manager; for example, manager1. If the call-routing software determines that the call should be presented to the assistant because manager1 cannot accept the call, the call routes to the proxy line that is configured for manager1 on the assistant Cisco Unified IP Phone.

You can manually configure a line on the assistant phone to serve as the proxy line, or you can use automatic configuration to generate a DN and to add the line to the assistant phone.

For information about configuring shared and intercom lines for Cisco Unified Communications Manager Assistant with shared line mode, see the [“Configuring Shared and Incoming Intercom Lines for the Assistant”](#) section on page 10-24.

When you display Cisco Unified Communications Manager Assistant information for the assistant, the system generates DNs on the basis of Cisco IP Manager Assistant service parameter entries in the Proxy Directory Number Range and Proxy Directory Prefix sections. For more information about these service parameters, see the [“Setting the Service Parameters for Cisco Unified Communications Manager Assistant”](#) section on page 9-22.

Perform the following procedure to configure the proxy and incoming intercom line appearances for an assistant. To configure a new user, see the [“Configuring an End User”](#) section in the *Cisco Unified Communications Manager Administration Guide*.



Tip

Before configuring the Cisco Unified Communications Manager Assistant information for an assistant, you must configure the manager information and assign an assistant to the manager. See [“Configuring a Manager and Assigning an Assistant for Proxy Line Mode”](#) section on page 9-32.

Before You Begin

If you want to automatically configure the proxy line on the assistant phone, configure the service parameters in the Proxy Directory Number Range and Proxy Directory Number Prefix sections.

Procedure

-
- Step 1** To configure an assistant and assign proxy and incoming intercom lines, choose **User Management > End User**.
 - Step 2** To find the user that will be the assistant, click the **Find** button or enter the user name in the Search Options field and click the **Find** button.
 - Step 3** To display user information for the chosen assistant, click the user name.
The End User Configuration window displays.
 - Step 4** To configure Cisco Unified Communications Manager Assistant information for the assistant, choose **Assistant Configuration** from the Related Links drop-down list box and click **Go**.
The Assistant Configuration window displays.
 - Step 5** From the Device Name drop-down list box, choose the device name to associate with the assistant.
 - Step 6** From the Intercom Line drop-down list box, choose the incoming intercom line appearance for the assistant.
 - Step 7** From the Primary Line drop-down list box, choose the primary line appearance for the assistant.
 - Step 8** Use the selection boxes in the Manager Association to Assistant Line area to assign and associate manager line numbers to the assistant line numbers.

In the Available Lines selection box, choose the assistant line. The word “Auto” precedes the autogenerated proxy lines. If you want Cisco Unified Communications Manager to create an autogenerated proxy line on the assistant phone, choose an autogenerated proxy line and ensure that the **Automatic Configuration** check box is checked.



Note The system automatically sets the softkey template as well as the calling search space and partition for existing proxy lines and intercom line on the basis of the Cisco IP Manager Assistant service parameter settings when the Automatic Configuration check box is checked. Additionally, the system sets auto answer with speakerphone for intercom line.

- Step 9** In the Manager Names selection box, choose the manager for whom this proxy line will apply.
- Step 10** In the Manager Lines selection box, choose the manager line for which this proxy line will apply.
- Step 11** Click the **Save** button.

The update takes effect immediately. If you chose automatic configuration, the assistant device automatically resets.

Additional Information

See the [“Related Topics” section on page 9-42](#).

Deleting the Cisco Unified Communications Manager Assistant Information from the Assistant

Perform the following procedure to delete Cisco Unified Communications Manager Assistant information for an assistant. To delete non-Cisco Unified Communications Manager Assistant information for an assistant, see the [“Configuring an End User”](#) section in the *Cisco Unified Communications Manager Administration Guide*.

Procedure

- Step 1** To search for the assistant for whom you want to delete Cisco Unified Communications Manager Assistant information, choose **User Management > End User** from Cisco Unified Communications Manager Administration.
- Step 2** From the Find and List Users window, click the **Find** button or enter the user name in the Search Options field and click the **Find** button.
- A list of configured users displays.
- Step 3** Choose the assistant whose information you want to delete.
- Step 4** From the Related Links drop-down list box, click **Assistant Configuration**.
- The Assistant Configuration window displays.
- Step 5** Click the **Delete** button.
- The update takes effect immediately.

**Note**

When non-Cisco Unified Communications Manager Assistant changes such as name, user locale, or PIN, are made to a user, the user (manager or assistant) must log out of Cisco Unified Communications Manager Assistant and log in before the changes occur.

Additional Information

See the [“Related Topics”](#) section on page 9-42.

Updating the Assistant Cisco Unified Communications Manager Assistant Configuration

Perform the following procedure to update Cisco Unified Communications Manager Assistant information for an assistant. To update non-Cisco Unified Communications Manager Assistant information for an assistant, see the [“Configuring an End User”](#) section in the *Cisco Unified Communications Manager Administration Guide*.

Procedure

-
- Step 1** To search for the assistant for whom you want to update information, choose **User Management > End User** from Cisco Unified Communications Manager Administration.
- Step 2** From the Find and List Users window, click the **Find** button or enter the user name in the Search Options field and click the **Find** button.
- A list of configured users displays.
- Step 3** Choose the assistant whose information you want to update.
- Step 4** From the Related Links drop-down list box, click **Assistant Configuration**.
- The Assistant Configuration window displays.
- Step 5** Update the information such as device name, intercom line, or manager association information that you want changed.

**Note**

The system automatically configures the softkey template, subscription to the Cisco Unified Communications Manager Assistant phone service, calling search space and partition for Cisco Unified Communications Manager Assistant—Controlled selected lines and intercom line, and auto answer with speakerphone for intercom line for the manager phone based on the Cisco IP Manager Assistant service parameters when the **Automatic Configuration** check box is checked.

- Step 6** Click the **Save** button.
- The update takes effect immediately.

**Note**

When non-Cisco Unified Communications Manager Assistant changes such as name, user locale, or PIN, are made to a user, the user (manager or assistant) must log out of Cisco Unified Communications Manager Assistant and log in before the changes can occur.

Additional Information

See the “[Related Topics](#)” section on page 9-42.

Dial Rules Configuration

The administrator uses dial rules configuration to add and sort the priority of dialing rules. Dial rules for Cisco Unified Communications Manager Assistant automatically strip numbers from or add numbers to telephone numbers that the assistant dials from the directory search window in the Assistant Console. For example, a dial rule can automatically add the digit 9 in front of a 7-digit telephone number to provide access to an outside line.

The following sections provide additional information on application dial rules:

- [Application Dial Rules Configuration Design](#), *Cisco Unified Communications Manager System Guide*
- [Application Dial Rules Configuration Error Checking](#), *Cisco Unified Communications Manager System Guide*

Providing Information to Cisco Unified Communications Manager Assistant Managers and Assistants

Install the assistant console application for Cisco Unified Communications Manager Assistant by accessing a URL. The administrator sends the URL, in the “[Installing the Assistant Console Application](#)” section on page 9-39, to the assistant.



Note

The assistant console application installation program supports Netscape 7.1, Microsoft Internet Explorer 6, and Internet Explorer 7.

Installing the Assistant Console Application

The assistant console application installation supports Netscape 7.1 (or later), Internet Explorer 7, and Microsoft Internet Explorer 6. You can install the application on a PC that runs Windows 2000, Windows XP, or Windows Vista.

A previous 5.x or 6.x version of the assistant console application works with Cisco Unified Communications Manager 7.0, but if you decide to install the 7.0 plug-in, you must uninstall the previous 5.x or 6.x version of the assistant console application before you install the plug-in.

Previous versions of the assistant console application do not work with Windows Vista. If the PC runs Windows Vista, install the plug-in.

After you upgrade from Cisco Unified CallManager Release 4.x to Cisco Unified Communications Manager 7.0, you must install the assistant console plug-in. Before you install the plug-in, uninstall the 4.x version of the assistant console application.

To uninstall previous versions of the assistant console application (6.0(1), 4.x, or any 5.x version before 5.1(3)), choose **Start > ...Programs > Cisco Unified CallManager Assistant > Uninstall Assistant Console**.

To uninstall a 5.1(3) or 6.1(x) attendant console application, go to the Control Panel and remove it.



Tip The assistant console application requires that JRE1.4.2_05 exist in C:\Program Files\Cisco\Cisco Unified Communications Manager.

To install the assistant console application, perform the following procedure:

Procedure

- Step 1** From the PC where you want to install the assistant console application, browse to Cisco Unified Communications Manager Administration and choose **Application > Plugins**.
- Step 2** For the Cisco Unified Communications Manager Assistant plug-in, click the **Download** link; save the executable to a location that you will remember.
- Step 3** Locate the executable and run it.



Tip If you install the application on a Windows Vista PC, a security window may display. Allow the installation to continue.

The installation wizard displays.

- Step 4** In the Welcome window, click **Next**.
- Step 5** Accept the license agreement and click **Next**.
- Step 6** Choose the location where you want the application to install. After you choose the location for the installation, click **Next**.



Tip By default, the application installs in C:\Program Files\Cisco\ Unified Communications Manager Assistant Console.

- Step 7** To install the application, click **Next**.
The installation begins.
- Step 8** After the installation completes, click **Finish**.



Tip To launch the assistant console, click the desktop icon or choose **Cisco Unified Communications Manager Assistant > Assistant Console** in the Start...Programs menu.

Before the assistant logs in to the console, give the assistant the port number and the IP address or hostname of the Cisco Unified Communications Manager server where the Cisco IP Manager Assistant service is activated. The first time that the assistant logs in to the console, the assistant must enter the information in the Cisco Unified Communications Manager Assistant Server Port and the Cisco Unified Communications Manager Assistant Server Hostname or IP Address fields.

Before the assistant logs in to the console, give the assistant the user name and password that is required to log in to the console.

The Advanced tab in the Cisco Unified Communications Manager Assistant Settings window allows you to enable trace for the assistant console.

Assistant Console Dialog Options

The assistant console displays a dialog that contains the following options:

- Location to Install—The path of the directory where the assistant console software gets installed. The default specifies following path:
c:\Program Files\Cisco\Cisco Unified Communications Manager Assistant Console
- Create Desktop Shortcut—Default specifies true. This parameter determines whether a shortcut is created on the assistant console.
- Create StartMenu Shortcut—Default specifies true. This parameter determines whether a shortcut is created in the Start menu (**Start > Programs > Cisco Unified Communications Manager Assistant > Assistant Console**).
- Install JRE—Default specifies true. This parameter determines whether JRE is installed along with assistant console. If this option is turned off, the following configuration must exist on the assistant console:
 - Install JRE 1.4.2_05 (international version) on the assistant console.
 - Create an environment variable—Assistant_JRE on the assistant console, which gives the path to the JRE; for example, c:\Program Files\Java\j2re1.4.2_05.

Manager Configuration

Managers can customize their feature preferences from the Manager Configuration window by using the following URL:

https://<Cisco Unified Communications Manager Assistant server>:8443/ma/desktop/maLogin.jsp
where

Cisco Unified Communications Manager Assistant server specifies the IP address of the server on which the Cisco IP Manager Assistant service is running.



Note

The Manager Configuration only supports Microsoft Internet Explorer (IE) 6 and Internet Explorer 7.

The administrator must send this URL to the manager.

Additional Information

See the [“Related Topics” section on page 9-42](#).

Related Topics

- [Softkey Templates](#), *Cisco Unified Communications Manager System Guide*
- [Cisco Unified Communications Manager Assistant With Shared Line Support](#), page 10-1
- [Cisco IP Manager Assistant Service](#), page 9-3
- [Cisco Unified IP Phone Interface](#), page 9-5
- [Cisco Unified Communications Manager Assistant Configuration Wizard](#), page 9-17
- [Cisco Unified IP Phone Service Configuration](#), page 9-27
- [Nonmanager and Nonassistant Phones](#), page 9-31
- [Configuring a Manager and Assigning an Assistant for Proxy Line Mode](#), page 9-32
- [Deleting Cisco Unified Communications Manager Assistant Information from the Manager](#), page 9-34
- [Updating the Manager Cisco Unified Communications Manager Assistant Configuration](#), page 9-34
- [Configuring Proxy, Incoming Intercom, and Primary Lines for the Assistant](#), page 9-35
- [Deleting the Cisco Unified Communications Manager Assistant Information from the Assistant](#), page 9-37
- [Configuring an End User](#), *Cisco Unified Communications Manager Administration Guide*
- [Associating Devices to an End User](#), *Cisco Unified Communications Manager Administration Guide*
- [Intercom](#), page 22-1

Additional Cisco Documentation

- *Cisco Unified Communications Manager Assistant User Guide*
- *Cisco Unified Communications Manager Administration Guide*
- *Cisco Unified Serviceability Administration Guide*
- *Cisco Unified Communications Manager Bulk Administration Guide*
- *Cisco Unified Communications Manager Security Guide*